



Declaration of Conformity



Type of equipment: LCD MONITOR
Brand Name /Trade Mark: HANWHA
Type designation /model: SMT-2233
Applicant: Hanwha Techwin Company Limited

In accordance with the following Directives:

2004/108/EC The Electromagnetic Compatibility Directive
Including amendments by the CE Marking Directive 93/68/EEC

2011/65/EU Restriction of the use of certain hazardous substances in electrical and electronic equipment (recast)

The following harmonized European standards or technical specifications have been applied:

EN 55022:2010	Limits and methods of measurement of radio disturbance characteristics of information technology equipment
EN 55024:2010	Limits and methods of measurement of Immunity characteristics of Information technology equipment
EN 61000-3-2:2014	Limits – Limits for harmonic current emissions (equipment input current \leq 16 A per phase)
EN 61000-3-3:2013	Limitation of voltage changes, voltage fluctuations and flicker in public low-voltage supply systems, for equipment with rated current \leq 16 A per phase and not subject to conditional connection
EN 61000-4-2:2009	Electrostatic discharge immunity test
EN 61000-4-3:2006+A2:2010	Radiated, radio-frequency, electromagnetic field immunity test
EN 61000-4-4:2012	Electrical fast transient/burst immunity test
EN 61000-4-5:2014	Surge immunity test
EN 61000-4-6:2009	Immunity to conducted disturbances, induced by radio-frequency fields
EN 61000-4-11:2004	Voltage dips, short interruptions and voltage variations immunity tests

The CE Marking on the products and/or their packaging signifies that Hanwha Techwin Company Limited holds the reference technical file available to the European Union authorities.

Place and date of issue: 1204, Changwon-daero, Seongsan-gu, Chang-won-si, Gyeongsangnam-do, Korea / Oct 08, 2015

Authorized Signatory: Name : Jei Soon, Kang
Title : Principal Research Engineer

Signatur :

CE Conformance EMC Test Report

Test Report No. : KES-E1-15T0278
Date of Issue : 10. 08. 2015
Description of Product : LCD MONITOR
Model No. : SMT-2233
Variant Model : -
Applicant : Hanwha Techwin Company Limited
Address : 1204, Changwon-daero, Seongsan-gu, Chang-won-si, Gyeongsangnam-do, Korea
Manufacturer : Weihai Daewoo Electronics Co.,Ltd.
Address : No.26, Hongkong Road, Economic & Technical Development Zone, 264205 Weihai City, Shandong Province, China
Applicable Regulation : **EMC Directive 2004/108/EC**
EN 55022:2010
EN 55024:2010
EN 61000-3-2:2014
EN 61000-3-3:2013

Date of Receipt : 09. 14. 2015
Test Date : 10. 02. 2015 ~ 10. 05. 2015

Tested by:



Kang Hyeon, Kim
Test Engineer

Reviewed by:



Dong Hun, Jang
Technical Manager



Testing Laboratories for Safety and RF Compliance
C-3701 40, Simin-daero 365beon-gil, Dongan-gu, Anyang-si, Gyeonggi-do, 14057, Korea
Tel: +82-31-425-6200 / Fax: +82-31-424-0450

Testing Laboratories for EMC Compliance
473-29, Gayeoro, Yeosu-si, Gyeonggi-do, 12658, Korea
Tel : +82-31-883-5092 / Fax: +82-31-883-5169



KES Co., Ltd.

C-3701, 40, Simin-daero 365beon-gil,
Dongan-gu, Anyang-si, Gyeonggi-do, 14057, Korea
Tel: +82-31-425-6200 / Fax: +82-31-424-0450
www.kes.co.kr

Test report No.:
KES-E1-15T0278
Page (2) of (106)

Revision history

Revision	Date of issue	Test report No.	Description
-	10. 08. 2015	KES-E1-15T0278	Initial

This report shall not be reproduced except in full, without the written approval of KES Co., Ltd.
The test results in the report only apply to the tested sample.

TABLE OF CONTENTS

1	General Information	4
2	Product Labelling Requirements	9
3	Applicable Regulations	11
4	Test standards and results	13
5	Test Performed	14
5.1	Conducted Emission Measurements	14
5.2	Radiated Emission Measurements	24
5.3	Harmonics / Voltage Fluctuations Measurements	40
5.4	Electrostatic Discharge Immunity	49
5.5	Radio-frequency electromagnetic field Amplitude modulated Immunity	52
5.6	Fast Transients Immunity	56
5.7	Surge Immunity	61
5.8	Radio-frequency continuous conducted Immunity	64
5.9	Voltage Dips and Interruptions Immunity	67
6	Test Setup Photographs	70
6.1	Conducted Emission	70
6.2	Radiated Emission	74
6.3	Harmonics / Voltage Fluctuations Measurements	80
6.4	Electrostatic Discharge Immunity	82
6.5	Radio frequency electromagnetic field immunity	87
6.6	Fast Transients Immunity	89
6.7	Surge Immunity	91
6.8	Radio-frequency continuous conducted Immunity	93
6.9	Voltage Dips and Interruptions Immunity	95
7	External Photographs	97
8	Internal Photographs	99
	Appendix A	105
	Appendix B	106



1. General Information

1.1 Introduction

The EMC Test Report for CE Declaration of Conformity is prepared on behalf of named applicant in accordance with the EMC Directive(2004/108/EC) of the European Economic Community. The test results reported in this document relate only to the item that was tested.

All radiated emission, conducted emission measurements required by the EMC Directive were performed manually at KES Co., Ltd. (here in after called KES), 473-29, Gayeo-ro, Yeosu-si, Gyeonggi-do, 12658 KOREA.

The radiated emission measurements performed on 10 meter, Open Area Test Site, test range maintained by KES. Complete ANSI63.4;2009 description and site attenuation measurement data records are maintained at the test facility and have been placed on file with the Federal Communications Commission.

All immunity measurements required by the EMC Directive were performed manually at KES Co., Ltd. (here in after called KES), 473-29, Gayeo-ro, Yeosu-si, Gyeonggi-do, 12658 KOREA.

The immunity measurements were performed in a shielded enclosure and/or anechoic chamber also located at the same facility.

The KES EMC test facilities in Yeosu-si are designated testing laboratory according to ISO/IEC 17025 by Radio Research Agency(RRA), Korea Communication Commission.

1.2 Product Description for Equipment Under Test (E.U.T)

Hanwha Techwin Company Limited, LCD MONITOR, Model No: SMT-2233 or the "E.U.T" as referred to in this report is base model.

Main Specifications of EUT are:

Model Name		SMT-2233	Remark
Display		LED	
Screen Size		22"	
Max. Resolution		1920 x 1080	
Brightness		250cd/m2	
Contrast Ratio		1,000 : 1	
Aspect Ratio		16:9	
Display		LED	
Screen size		22	
Viewing Angle (H/V)		170°/160°	
Display Color		16.7Million	
Response Time		5ms	
Video System		NTSC / PAL	
Panel Life		30,000 hours	
Filter Type		3D Combfilter	
Interface			
Video	Connector	BNC types: (2 in/2 out)	
RGB	Connector	One(1) Analog RGB 15-pin D-sub	
	Input signal	0.7 Vp-p ±5 %	
HDMI	Connector	One(1) HDMI input (type A connector)	
Audio	Connector	Two(2) RCA type (2 stereo inputs)	
	Output signal	Speakers: two(2) x 1 W	
Application Support		Remote Controller	
On Screen Display		Samsung UI	
Functions		VESA™ DPM Compatible	
Language		English, Spanish, French, German, Italian, Portuguese, Russian Swedish, Turkish, Thai,Dutch,Danish,Arabic,Chinese, Japanese, Korea	
General			
Electrical	Input Voltage	AC100 ~ 240V (50/60Hz)	
	Power consumption	24w	
Environmenta	Operating Temperature	0 ~ +40°C (+32°F ~ +104°F)	
	Humidity	20% – 90% (non-condensing)	
Mechanical	Dimensions with Stand (WxHxD)	515mm x 391.8mm x 217.4mm	
	Dimensions without Stand (WxHxD)	515mm x 316mm x 59.9mm	
	Weight	5.2kg	
	LCD Protection Glass	Yes	
	Cabinet Color	Black	
VESA Mounts Interface		100mm x 100mm	

This report shall not be reproduced except in full, without the written approval of KES Co., Ltd.
The test results in the report only apply to the tested sample.



1.3 Equipment Under Test

Description	Model Number	Serial Number	Manufacturer	Remarks
LCD MONITOR	SMT-2233	-	Weihai Daewoo Electronics Co.,Ltd.	EUT
Remote control	-	-	SAMSUNG	

1.4 Support Equipments

Description	Model Number	Serial Number	Manufacturer	Remarks
Notebook	NT63025J	JK9091EF400432X	SAMSUNG	-
Switching Adapter	A13-040N2A	CN60BA4400313AD0N8 43KO243	Chicony Power Techology (suzhou) Co., Ltd.	-
Camera	-	-	-	-
Adapter	JPW115KA1200M03	-	MANUFACT URED BY Bridge power Corp.	-
Monitor	SMT-1935	-	Weihai Daewoo Electronics Co.,Ltd.	-

1.5 External I/O Cabling

Start		END		Cable Spec.	
Description	I/O Port	Description	I/O Port	Length	Shield
LCD MONITOR (E.U.T)	D-SUB	Notebook	D-SUB	1.4	Shielded
	HDMI	Notebook	HDMI	1.2	Shielded
	BNC	Camera	BNC	1.0	Shielded
	BNC	Monitor	BNC	4.0	Shielded
	Audio	Cable Termination	Audio	0.4	Shielded

This report shall not be reproduced except in full, without the written approval of KES Co., Ltd.
The test results in the report only apply to the tested sample.

1.6 Special Accessories

As shown in section 1.9, all interface cables used for compliance testing are shielded as normally supplied or by use respective component manufacturers.

1.7 E.U.T Modifications

No modifications were made to the E.U.T in order to achieve and maintain compliance to the standards described in this report.

1.8 Configuration of Test System

■ D-SUB, HDMI Mode

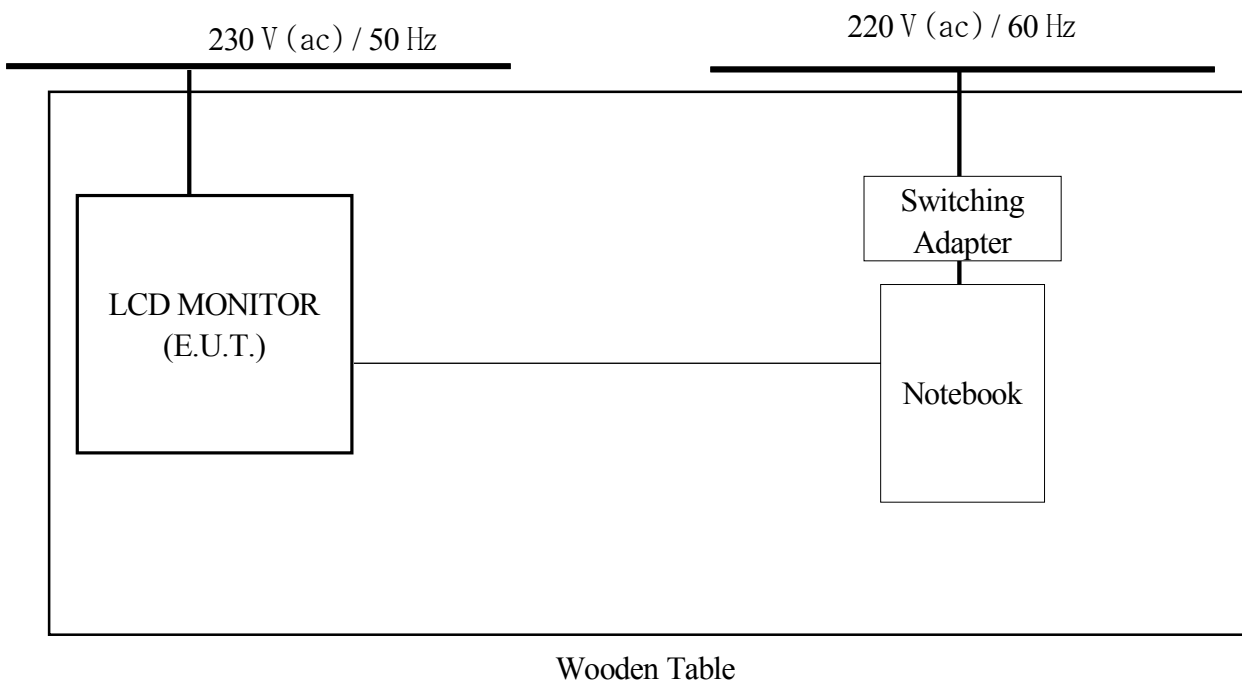

■ **Video Mode Mode**

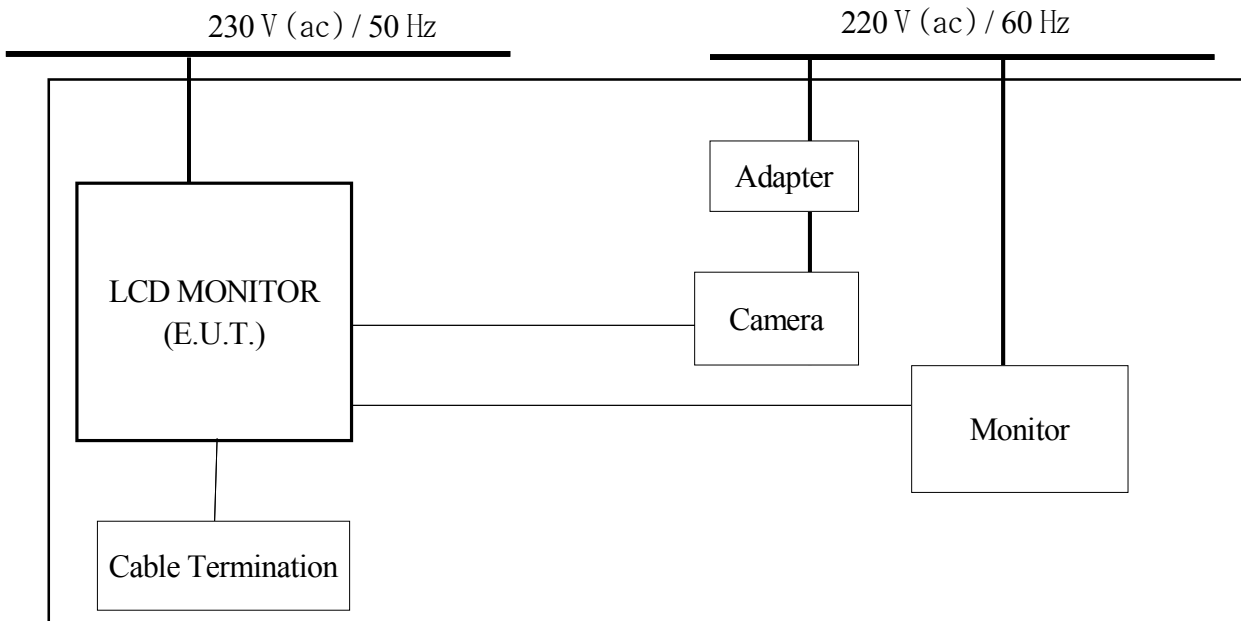

Wooden Table

1.9 Operating condition

- D-SUB, HDMI Mode

Normal operation

- Video Mode Mode

Normal operation

3. Applicable Regulations

3.1 Emission

EN 55022:2010/CISPR22 are the applicable regulations that apply to Information Technology Equipment. The intention of these standards, is to establish uniform requirements for the radio disturbance level of the equipment contained in the scope, to fix limits of disturbance, to describe method of measurement and to standardize operation conditions and interpretation of the results.

EN 55022:2010/CISPR22 defines Information Technology Equipment (ITE) as follows:

Any equipment which has a primary function of either (or a combination of) entry, storage, display, retrieval, transmission, processing, switching, or control, of data and of telecommunication message and which may be equipped with one or more terminal ports typically operated for information transfer.

Any equipment with a rated supply voltage not exceeding 600 V (ac)

3.2 Immunity

EN 50130-4:2011 Alarm systems-Part 4: Electromagnetic compatibility Product family standard: Immunity requirements for components of fire, intruder and social alarm systems

The variety and the diversity of the apparatus within the scope of this document makes it difficult to define precise criteria for the evaluation of the immunity test results.

If as a result of the application of the tests defined in this standard, the apparatus becomes dangerous or unsafe then the apparatus shall be deemed to have failed the test.

A functional description and a definition of performance by the manufacture and noted in the test report, based on the following criteria:

Electrostatic discharge

There shall be no damage, malfunction or change of status due to the conditioning.

Flickering of an indicator during the application of discharge is permissible, providing that is no residual change in the EUT or any change in outputs, which could be interpreted by associated equipment as a change.

Radiated electromagnetic fields

There shall be no damage, malfunction or change of status due to the conditioning.

Flickering of an indicator during the application of discharge is permissible, providing which could be interpreted by associated equipment as a change, and no such

Flickering of indicators occurs at a field strength of 3 V/m.

For components of CCTV systems, where the picture is allowed at 10 V/m, providing.

- (a) there is no permanent damage or change to EUT
(e.g. no corruption of memory or changes to programmable setting etc.)
- (b) at 3 V/m, any deterioration of the picture is so minor that the system could still be used; and
- (c) there is no observable deterioration of the picture at 1 V/m.

Fast transient burst / slow high energy voltage surge

There shall be no damage, malfunction or change of status due to the conditioning.

Flickering of an indicator during the application of discharge is permissible, providing

That there is no residual is permissible, providing that there is no residual change in the EUT or any change in outputs, which could be interpreted by associated equipment as a change.

Conducted RF immunity

There shall be no damage, malfunction or change of status due to the conditioning.

Flickering of an indicator during the application of discharge is permissible, providing

That there is no residual is permissible, providing that there is no residual change in the EUT or any change in outputs, which could be interpreted by associated equipment as a change,
and no such flickering of indicators occurs at $U = 130 \text{ dB}\mu\text{V}$.

For component of CCTV systems, where the status is monitored by observing the TV picture, then deterioration of the picture is allowed at $U = 140 \text{ dB}\mu\text{V}$, providing:

- (a) there is no permanent damage or change to the EUT
(e.g. no corruption of memory or changes to programmable settings etc.)
- (b) at $U = 130 \text{ dB}\mu\text{V}$, any deterioration of the picture is so minor that the system could still be used; and
- (c) there is no observable deterioration of the picture at $U = 120 \text{ dB}\mu\text{V}$.

Voltage dip/interruption / Voltage variation

There shall be no damage, malfunction or change of status due to the conditioning.

Flickering of an indicator during the conditioning is permissible, providing that there is no residual change in the EUT or any change in outputs, which could be interpreted by associated equipment as a change. The EUT shall meet the acceptance criteria for the functional test, after the conditioning.



4. Test standards DLDU and results

STANDARDS		LIMIT	RESULTS
EN 55022	Conducted Emission on AC mains Port	Refer to EN 55022	PASS
	Conducted Emission on Telecommunication Port	Refer to EN 55022	N/A
	Radiated Emission	Refer to EN 55022	PASS
EN 61000-3-2	Harmonic Current Emission on AC Mains Input Port	Refer to EN 61000-3-2	PASS
EN 61000-3-3	Voltage Fluctuations and Flicker on AC Mains Input Port	Refer to EN 61000-3-3	PASS
EN 55024	Electrostatic Discharge Immunity	Refer to EN 61000-4-2	PASS
	Radio-frequency electromagnetic field Amplitude modulated Immunity	Refer to EN 61000-4-3	PASS
	Fast Transients Immunity	Refer to EN 61000-4-4	PASS
	Surges Immunity	Refer to EN 61000-4-5	PASS
	Radio-frequency common mode Immunity	Refer to EN 61000-4-6	PASS
	Power-frequency magnetic field Immunity	Refer to EN 61000-4-8	N/A
	Voltage Dips, Voltage Interruptions Immunity	Refer to EN 61000-4-11	PASS

This report shall not be reproduced except in full, without the written approval of KES Co., Ltd.
 The test results in the report only apply to the tested sample.

5. Test Performed

5.1 Conducted Emission Measurements

5.1.1 Test Description

The power line conducted emission measurements were performed in a shielded enclosure. The E.U.T was placed on a wooden table, 80 centimeters height above the floor. Power was fed to the E.U.T through a 50 ohm/ 50 micro henry Line Impedance Stabilization Network (LISN). The ground plane that was electrically bonded to the shield room ground system and all power lines entering the shield room were filtered.

5.1.2 Test Equipments

Description	Manufacturer	Model Number	Serial Number	Cal. Due
EMI Test Receiver	Rohde & Schwarz	ESR3	101783	05. 06. 2016
LISN	Rohde & Schwarz	ENV216	101137	02. 10. 2016
LISN	Rohde & Schwarz	ENV216	101786	05. 06. 2016
Electro wave Shieldroom	SEMITEC	-	-	-

5.1.3 Test Environments

Ambient Temperatures	Relative Humidity
see the data	see the data

5.1.4 Test Limits

- AC Main

Frequency (MHz)	EN 55022			
	Class B (dB μ V)		Class A (dB μ V)	
	Quasi-peak	Average	Quasi-peak	Average
0.15 to 0.50	66.0 to 56.0	56.0 to 46.0	79.0	66.0
0.50 to 5.00	56.0	46.0	73.0	60.0
5.00 to 30.00	60.0	50.0	73.0	60.0

- Telecommunication

Frequency (MHz)	EN 55022(Voltage)			
	Class B (dB μ V)		Class A (dB μ V)	
	Quasi-peak	Average	Quasi-peak	Average
0.15 to 0.50	84.0 to 74.0	74.0 to 64.0	97.0 to 87.0	84.0 to 74.0
0.50 to 30.00	74.0	64.0	87.0	74.0

Frequency (MHz)	EN 55022(Current)			
	Class B (dB μ A)		Class A (dB μ A)	
	Quasi-peak	Average	Quasi-peak	Average
0.15 to 0.50	40.0 to 30.0	30.0 to 20.0	53.0 to 43.0	40.0 to 30.0
0.50 to 30.00	30.0	20.0	43.0	30.0

5.1.5 Test Procedure

The conducted emission levels were measured on each current-carrying line with the spectrum analyzer operating in the CISPR quasi-peak mode (or peak mode if applicable). The analyzer's 6 dB bandwidth was set to 9 kHz. The initial step in collecting conducted data is a spectrum analyzer peak scan of the measurement range. If the conducted emission exceed the average limit with the instrument set to the quasi-peak mode, the measurements are made in the average mode. The emission spectrum was scanned from 150 kHz to 30 MHz. The highest emission amplitudes relative to the appropriate limits were measured and have been recorded. Quasi-peak readings are distinguished with a "QP".

The conducted emission test was performed with the E.U.T exercise program loaded, and the emissions were scanned between 150 kHz to 30 MHz on the HOT side and NEUTRAL side, herein referred to as H and N, respectively.

5.1.6 Test Results

According to the data in section 5.1.7, the E.U.T complied with the EN 55022/CISPR22 standards.

5.1.7 Test Data

Temperature: 22.8 °C Humidity: 38.5 % R.H. Test Date: 10. 02. 2015 Tested by: Kang Hyeon, Kim

■ D-SUB Mode

Polarization: HOT

Test Description: Conducted Emission
 Model No.: SMT-2233
 Mode: D-SUB
 Operator Name: KES

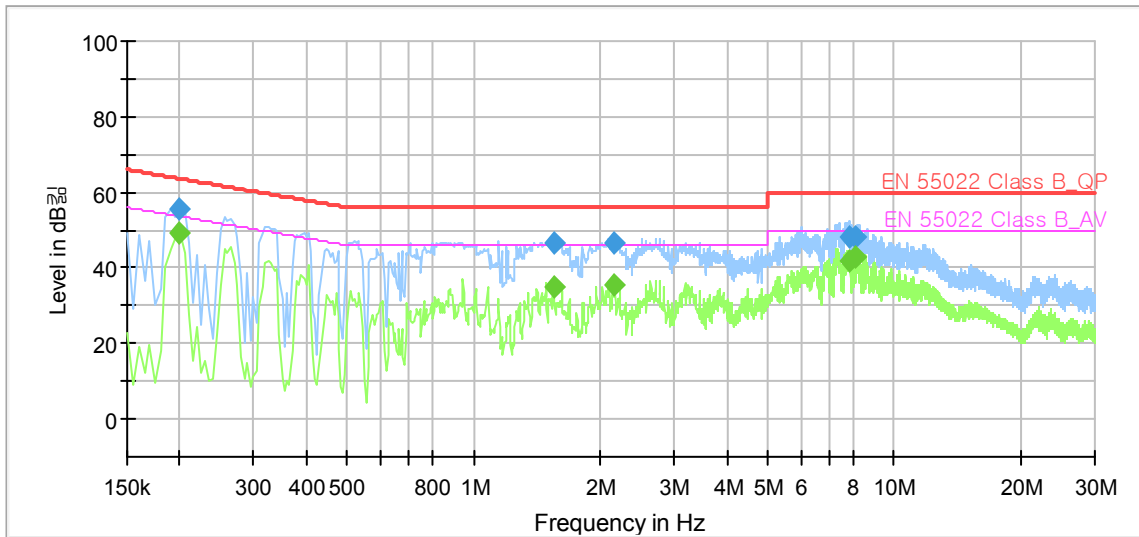

Final Result

Frequency (MHz)	QuasiPeak (dBµV)	CAverage (dBµV)	Limit (dBµV)	Margin (dB)	Meas. Time (ms)	Bandwidth (kHz)	Line	Corr. (dB)
0.200000	---	49.24	53.61	4.37	1000.0	9.000	L1	9.7
0.200000	55.52	---	63.61	8.09	1000.0	9.000	L1	9.7
1.555000	---	34.97	46.00	11.03	1000.0	9.000	L1	9.7
1.555000	46.47	---	56.00	9.53	1000.0	9.000	L1	9.7
2.165000	---	35.33	46.00	10.67	1000.0	9.000	L1	9.7
2.165000	46.68	---	56.00	9.32	1000.0	9.000	L1	9.7
7.840000	---	41.62	50.00	8.38	1000.0	9.000	L1	9.9
7.840000	48.21	---	60.00	11.79	1000.0	9.000	L1	9.9
8.050000	---	43.04	50.00	6.96	1000.0	9.000	L1	9.9
8.050000	48.20	---	60.00	11.80	1000.0	9.000	L1	9.9

Polarization: NEUTRAL

Test Description: Conducted Emission
 Model No.: SMT-2233
 Mode: D-SUB
 Operator Name: KES

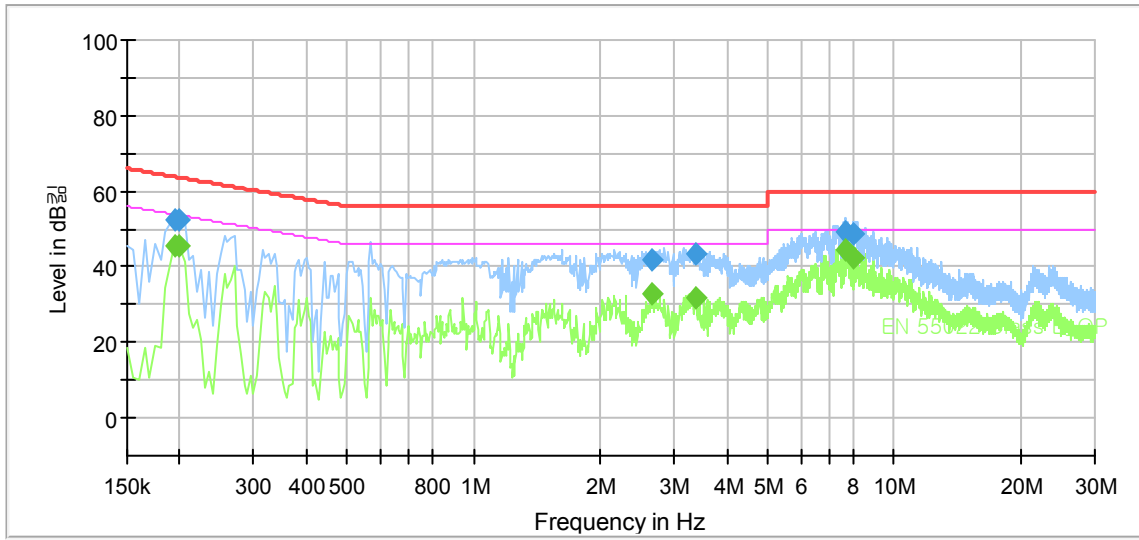

Final Result

Frequency (MHz)	QuasiPeak (dBµV)	CAverage (dBµV)	Limit (dBµV)	Margin (dB)	Meas. Time (ms)	Bandwidth (kHz)	Line	Corr. (dB)
0.195000	---	45.55	53.82	8.27	1000.0	9.000	N	9.7
0.195000	52.54	---	63.82	11.28	1000.0	9.000	N	9.7
0.200000	---	45.28	53.61	8.33	1000.0	9.000	N	9.7
0.200000	52.45	---	63.61	11.16	1000.0	9.000	N	9.7
2.640000	---	32.60	46.00	13.40	1000.0	9.000	N	9.7
2.640000	42.00	---	56.00	14.00	1000.0	9.000	N	9.7
3.385000	---	31.75	46.00	14.25	1000.0	9.000	N	9.8
3.385000	43.26	---	56.00	12.74	1000.0	9.000	N	9.8
7.660000	---	44.52	50.00	5.48	1000.0	9.000	N	9.9
7.660000	49.48	---	60.00	10.52	1000.0	9.000	N	9.9
8.010000	---	42.24	50.00	7.76	1000.0	9.000	N	9.9
8.010000	48.68	---	60.00	11.32	1000.0	9.000	N	9.9

This report shall not be reproduced except in full, without the written approval of KES Co., Ltd.
 The test results in the report only apply to the tested sample.

■ HDMI Mode

Polarization: HOT

Test Description: Conducted Emission
 Model No.: SMT-2233
 Mode: HDMI
 Operator Name: KES

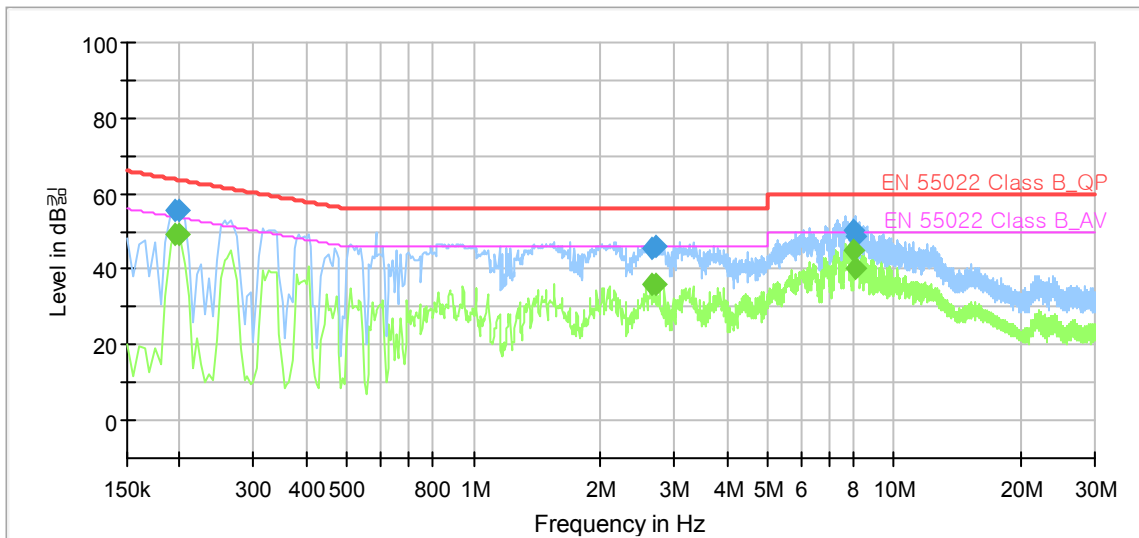

Final Result

Frequency (MHz)	QuasiPeak (dBµV)	CAverage (dBµV)	Limit (dBµV)	Margin (dB)	Meas. Time (ms)	Bandwidth (kHz)	Line	Corr. (dB)
0.195000	---	49.28	53.82	4.54	1000.0	9.000	L1	9.7
0.195000	55.36	---	63.82	8.46	1000.0	9.000	L1	9.7
0.200000	---	49.22	53.61	4.39	1000.0	9.000	L1	9.7
0.200000	55.38	---	63.61	8.23	1000.0	9.000	L1	9.7
2.640000	---	35.83	46.00	10.17	1000.0	9.000	L1	9.7
2.640000	45.31	---	56.00	10.69	1000.0	9.000	L1	9.7
2.710000	---	35.89	46.00	10.11	1000.0	9.000	L1	9.7
2.710000	46.16	---	56.00	9.84	1000.0	9.000	L1	9.7
8.015000	---	45.26	50.00	4.74	1000.0	9.000	L1	9.9
8.015000	50.17	---	60.00	9.83	1000.0	9.000	L1	9.9
8.065000	---	40.47	50.00	9.53	1000.0	9.000	L1	9.9
8.065000	48.69	---	60.00	11.31	1000.0	9.000	L1	9.9

This report shall not be reproduced except in full, without the written approval of KES Co., Ltd.
 The test results in the report only apply to the tested sample.

Polarization: NEUTRAL

Test Description: Conducted Emission
 Model No.: SMT-2233
 Mode: HDMI
 Operator Name: KES

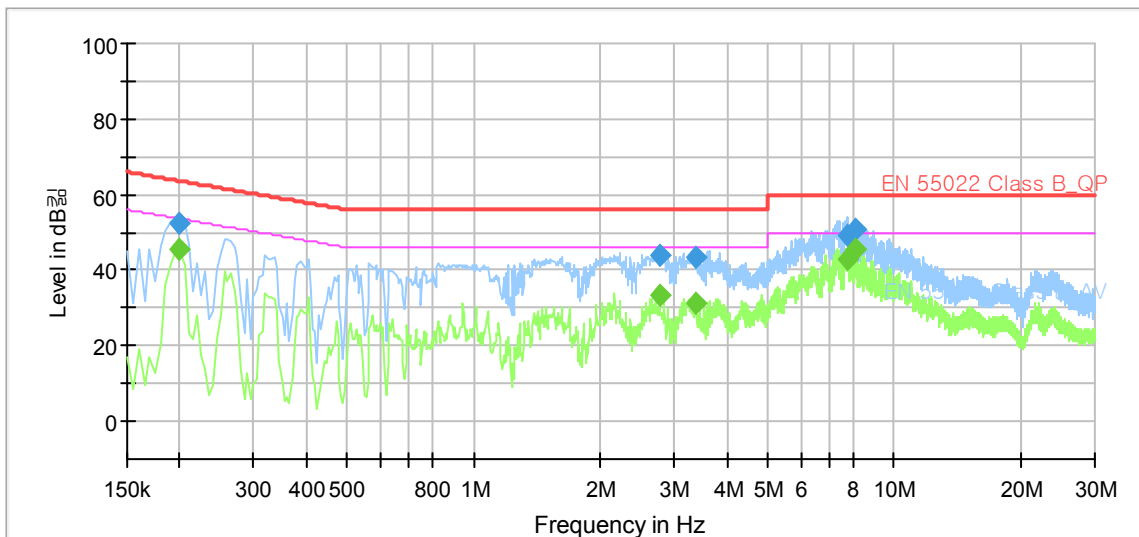

Final Result

Frequency (MHz)	QuasiPeak (dBµV)	CAverage (dBµV)	Limit (dBµV)	Margin (dB)	Meas. Time (ms)	Bandwidth (kHz)	Line	Corr. (dB)
0.200000	---	45.30	53.61	8.31	1000.0	9.000	N	9.7
0.200000	52.44	---	63.61	11.17	1000.0	9.000	N	9.7
2.775000	---	33.24	46.00	12.76	1000.0	9.000	N	9.7
2.775000	43.83	---	56.00	12.17	1000.0	9.000	N	9.7
3.385000	---	31.48	46.00	14.52	1000.0	9.000	N	9.8
3.385000	43.27	---	56.00	12.73	1000.0	9.000	N	9.8
7.770000	---	43.03	50.00	6.97	1000.0	9.000	N	9.9
7.770000	49.40	---	60.00	10.60	1000.0	9.000	N	9.9
8.045000	---	45.70	50.00	4.30	1000.0	9.000	N	9.9
8.045000	50.63	---	60.00	9.37	1000.0	9.000	N	9.9

This report shall not be reproduced except in full, without the written approval of KES Co., Ltd.
 The test results in the report only apply to the tested sample.

Video Mode

Polarization: HOT

Test Description: Conducted Emission
 Model No.: SMT-2233
 Mode: VIDEO
 Operator Name: KES

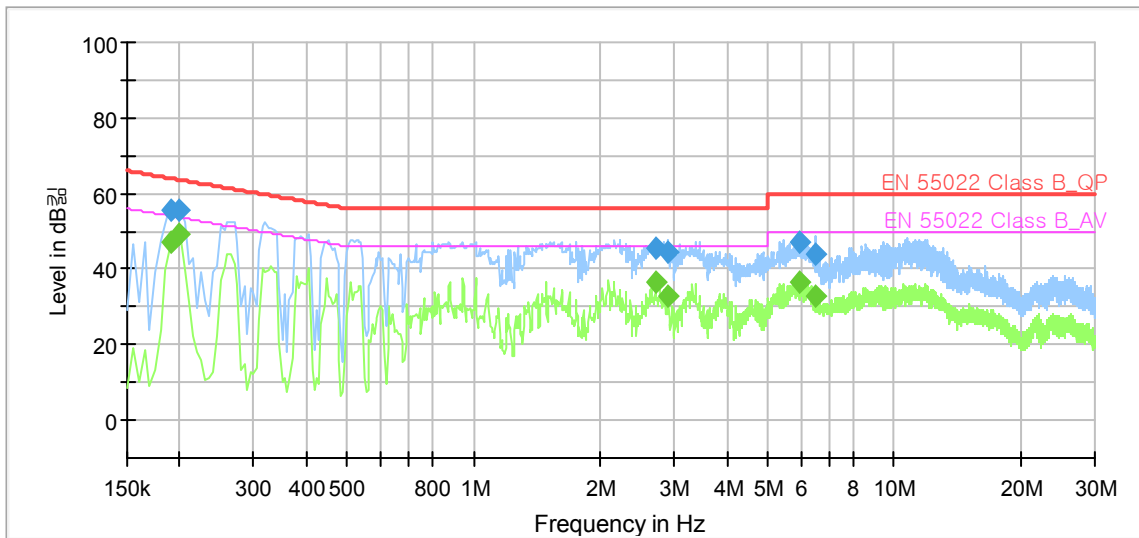

Final Result

Frequency (MHz)	QuasiPeak (dBµV)	CAverage (dBµV)	Limit (dBµV)	Margin (dB)	Meas. Time (ms)	Bandwidth (kHz)	Line	Corr. (dB)
0.190000	---	47.04	54.04	7.00	1000.0	9.000	L1	9.7
0.190000	55.46	---	64.04	8.58	1000.0	9.000	L1	9.7
0.200000	---	49.16	53.61	4.45	1000.0	9.000	L1	9.7
0.200000	55.42	---	63.61	8.19	1000.0	9.000	L1	9.7
2.705000	---	36.56	46.00	9.44	1000.0	9.000	L1	9.7
2.705000	45.64	---	56.00	10.36	1000.0	9.000	L1	9.7
2.905000	---	32.94	46.00	13.06	1000.0	9.000	L1	9.8
2.905000	44.54	---	56.00	11.46	1000.0	9.000	L1	9.8
5.950000	---	36.45	50.00	13.55	1000.0	9.000	L1	9.9
5.950000	47.16	---	60.00	12.84	1000.0	9.000	L1	9.9
6.495000	---	32.82	50.00	17.18	1000.0	9.000	L1	9.9
6.495000	44.15	---	60.00	15.85	1000.0	9.000	L1	9.9

This report shall not be reproduced except in full, without the written approval of KES Co., Ltd.
 The test results in the report only apply to the tested sample.

Polarization: NEUTRAL

Test Description: Conducted Emission
 Model No.: SMT-2233
 Mode: VIDEO
 Operator Name: KES

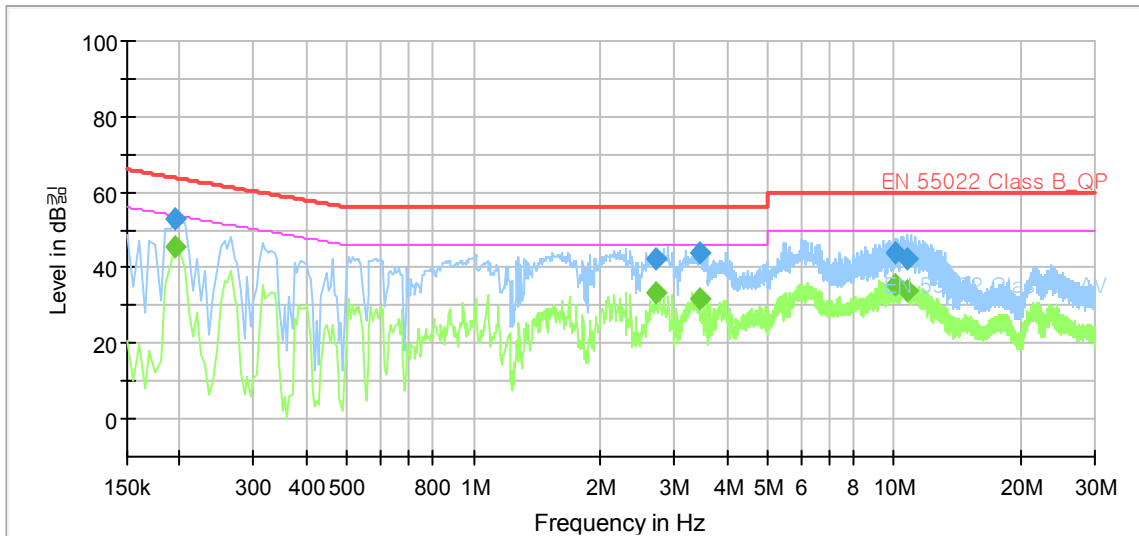

Final Result

Frequency (MHz)	QuasiPeak (dBµV)	CAverage (dBµV)	Limit (dBµV)	Margin (dB)	Meas. Time (ms)	Bandwidth (kHz)	Line	Corr. (dB)
0.195000	---	45.70	53.82	8.12	1000.0	9.000	N	9.7
0.195000	52.68	---	63.82	11.14	1000.0	9.000	N	9.7
2.705000	---	33.46	46.00	12.54	1000.0	9.000	N	9.7
2.705000	42.10	---	56.00	13.90	1000.0	9.000	N	9.7
3.450000	---	32.02	46.00	13.98	1000.0	9.000	N	9.8
3.450000	44.16	---	56.00	11.84	1000.0	9.000	N	9.8
10.010000	---	35.32	50.00	14.68	1000.0	9.000	N	10.0
10.010000	43.84	---	60.00	16.16	1000.0	9.000	N	10.0
10.750000	---	33.68	50.00	16.32	1000.0	9.000	N	10.0
10.750000	42.40	---	60.00	17.60	1000.0	9.000	N	10.0

This report shall not be reproduced except in full, without the written approval of KES Co., Ltd.
 The test results in the report only apply to the tested sample.



KES Co., Ltd.

C-3701, 40, Simin-daero 365beon-gil,
Dongan-gu, Anyang-si, Gyeonggi-do, 14057, Korea
Tel: +82-31-425-6200 / Fax: +82-31-424-0450
www.kes.co.kr

Test report No.:
KES-E1-15T0278
Page (22) of (106)

- Telecommunication

Temperature: °C Humidity: % R.H. Test Date: Tested by:

[10 Mbps]

N/A

This report shall not be reproduced except in full, without the written approval of KES Co., Ltd.
The test results in the report only apply to the tested sample.



KES Co., Ltd.

C-3701, 40, Simin-daero 365beon-gil,
Dongan-gu, Anyang-si, Gyeonggi-do, 14057, Korea
Tel: +82-31-425-6200 / Fax: +82-31-424-0450
www.kes.co.kr

Test report No.:
KES-E1-15T0278
Page (23) of (106)

[100 Mbps]

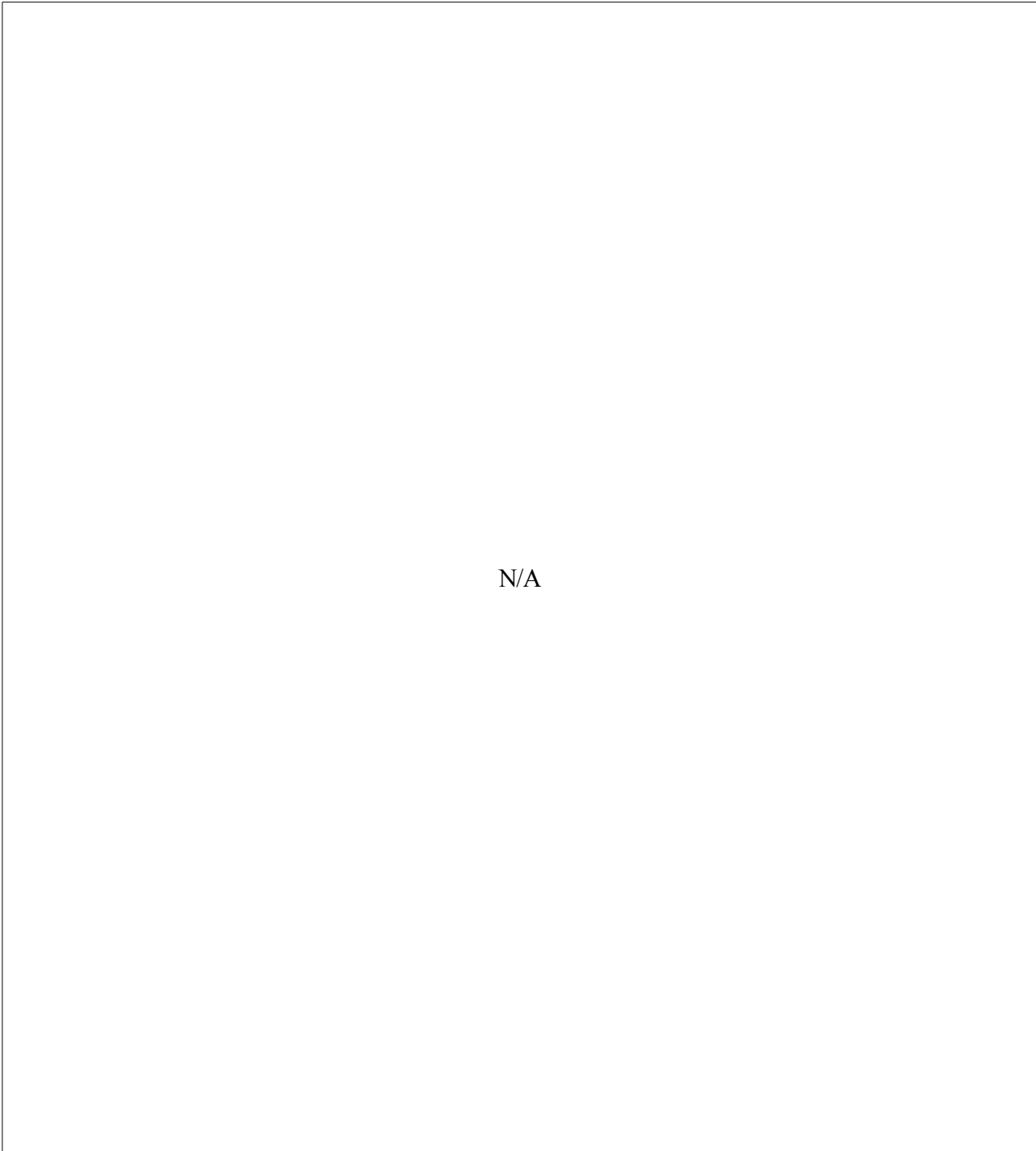

This report shall not be reproduced except in full, without the written approval of KES Co., Ltd.
The test results in the report only apply to the tested sample.

5.2 Radiated Emission Measurements

5.2.1 Test Description

The radiated emissions measurements were performed on the ten-meter open-field test site and 3 m full chamber. The E.U.T was placed on a nonconductive turntable approximately 0.8 meters above the ground plane.

The frequency spectrum from 30 MHz to 1 000 MHz and 1 000 MHz to 6 000 MHz was scanned and maximum emission levels at each frequency recorded.

The system was rotated 360°, and the antenna was varied in the height between 1.0 and 4.0 meters in order to determine the maximum emission levels. This procedure was performed for horizontal and vertical polarization of the receiving antenna.

- above 1 GHz : Antenna height is fixed to 1.0 m

* Below 1 GHz

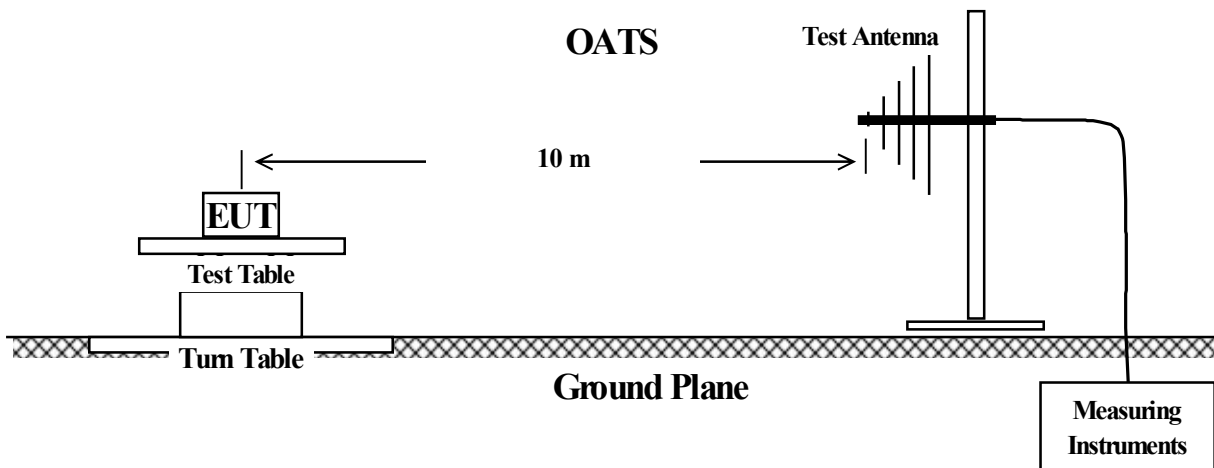

* Above 1 GHz

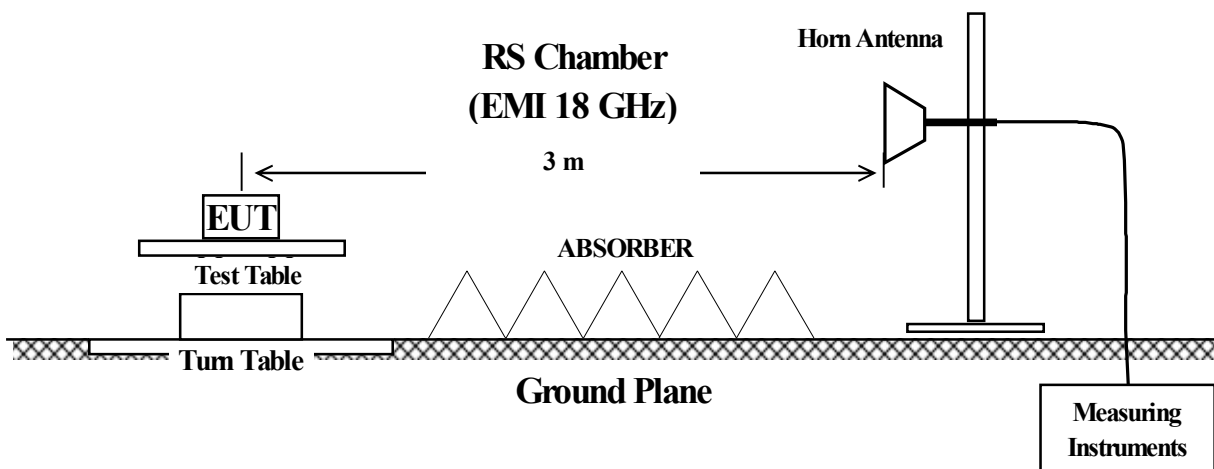

5.2.2 Test Equipments

Description	Manufacturer	Model Number	Serial Number	Cal. Due
EMI TEST Receiver	ESR3	Rohde & Schwarz	101781	05. 06. 2016
Trilog-Broadband Antenna	VULB 9163	SCHWARZBECK	9168-713	05. 15. 2017
OATS	KES	-	-	-
Antenna Mast	DAEIL EMC	-	-	-
Turn Table	DAEIL EMC	-	-	-
EMI TEST Receiver	ESU26	R & S	100552	05. 06. 2016
Broadband Coaxial Prempfier	A-H-SYSTEM,INC	SAS-571	781	05. 07. 2017
DOUBLE TIDGED HRON ANTENNA	Schwarzbeck Mess - Elektronik	BBV 9718	9718-246	10 .23. 2015
RS Chamber (EMI 18GHz)	SEMITEC		-	-

5.2.3 Test Environments

Ambient Temperatures	Relative Humidity
see the data	see the data

5.2.4 Test Limits

Frequency (MHz)	EN 55022	
	Class B @ 10 m (dB μ V/m)	Class A @ 10 m (dB μ V/m)
30 to 230	30.0	40.0
230 to 1 000	37.0	47.0

Frequency (MHz)	EN 55022			
	Class B @ 3 m (dB μ V/m)		Class A @ 3 m (dB μ V/m)	
	PK	AV	PK	AV
1 000 to 3 000	70	50	76	56
3 000 to 6 000	74	54	80	60

This report shall not be reproduced except in full, without the written approval of KES Co., Ltd.
The test results in the report only apply to the tested sample.

5.2.5 Test Procedure

Before final measurements of radiated emission were made on the OATS, the E.U.T was scanned in semi-anechoic chamber in order to determine its emission spectrum signature. The physical arrangement of the test system and associated cabling was varied in order to determine the effect on the E.U.T's emission in amplitude, direction and frequency. This process was repeated during final radiated emission measurements on the OATS range, at each frequency, in order to ensure that maximum emissions amplitudes were attained.

The radiated emission test was performed with E.U.T exercise program loaded, and the emissions were scanned between 30 MHz to 6 000 MHz using the spectrum analyzer. The spectrum analyzer's 6 dB bandwidth was set to 120 kHz(1 MHz), and the analyzer was operated in the CISPR quasi-peak(Peak) detection mode.

Measurements were taken using both HORIZONTAL and VERTICAL antenna polarization, herein referred to as H and V, respectively.

5.2.6 Field Strength Calculation

F.S = Field Strength

M.R = Meter Reading

A.F = Antenna Factor

C.L = Cable Loss

A.G= Amplifier Gain

* Below 1 GHz : $F.S(dB\mu V/m) = M.R(dB\mu V) + [A.F(dB/m) + C.L(dB)]$

* Above 1 GHz : $F.S(dB\mu V/m) = M.R(dB\mu V) + [A.F(dB/m) + C.L(dB)] - A.G$

* Measurement in the presence of high ambient signals

In general, the ambient signals should not exceed the limit. Radiated emanations from the EUT at the point of measurement may, however, be impossible to measure at some frequencies due to ambient noise fields generated by local broadcast services, other manmade devices, and natural sources.

a) Perform measurements at close-in distances and determine the limit L2 corresponding to the close-in distance d2 by applying the following relation:

$$L2 = L1 (d1/d2)$$

where L1 is the specified limit in microvolts per metre ($\mu V/m$) at the distance d1.
Determine the possible environmental and compliance test conditions stipulated in Clause 8 using L2 as the new limit for distance d2.

b) In the frequency bands where the ambient noise values of Clause 8 are exceeded (measured values higher than 6 dB below the limit), the disturbance values of the EUT may be interpolated from the adjacent disturbance values. The interpolated value shall lie on the curve describing a continuous function of the disturbance values adjacent to the ambient noise.

5.2.7 Test Results

According to the data in section 5.1.7, the E.U.T complied with the EN 55022/CISPR22 standards.

5.2.8 Test Data

* Below 1 GHz

Temperature: 20.0 °C Humidity: 54.0 % R.H. Test Date: 10. 02. 2015 Tested by: Kang Hyeon, Kim

■ D-SUB Mode

Frequency (MHz)	Amplitude (dB μ V/m)	Antenna		Correction Factor		Corrected Amplitude (dB μ V/m)	Applicable Limit (dB μ V/m)	Margin (dB)
		Polar. (H/V)	Height (m)	Ant. (dB)	Cable (dB)			
51.34	9.22	V	1.36	13.78	1.77	24.77	30.00	5.23
152.22	11.62	H	4.00	8.28	3.21	23.11	30.00	6.89
245.34	12.57	H	3.85	12.31	4.24	29.12	37.00	7.88
263.77	12.89	H	3.70	12.68	4.46	30.03	37.00	6.97
405.39	9.62	V	1.25	15.78	5.82	31.22	37.00	5.78
427.70	6.69	V	1.99	16.09	6.00	28.78	37.00	8.22

■ HDMI Mode

Frequency (MHz)	Amplitude (dB μ V/m)	Antenna		Correction Factor		Corrected Amplitude (dB μ V/m)	Applicable Limit (dB μ V/m)	Margin (dB)
		Polar. (H/V)	Height (m)	Ant. (dB)	Cable (dB)			
149.31	12.08	V	1.00	8.18	3.16	23.42	30.00	6.58
208.48	10.49	H	3.28	11.49	3.96	25.94	30.00	4.06
247.28	12.90	H	4.00	12.35	4.26	29.51	37.00	7.49
445.04	10.42	V	1.70	16.33	6.14	32.89	37.00	4.11

■ Video Mode

Frequency (MHz)	Amplitude (dB μ V/m)	Antenna		Correction Factor		Corrected Amplitude (dB μ V/m)	Applicable Limit (dB μ V/m)	Margin (dB)
		Polar. (H/V)	Height (m)	Ant. (dB)	Cable (dB)			
49.42	7.72	V	1.63	13.92	1.74	23.38	30.00	6.62
152.22	11.29	H	3.70	8.28	3.21	22.78	30.00	7.22
245.34	12.35	H	4.00	12.31	4.24	28.90	37.00	8.10
360.77	9.78	H	3.81	14.79	5.32	29.89	37.00	7.11
423.82	8.06	V	1.79	16.03	5.97	30.06	37.00	6.94
515.97	8.50	V	1.00	17.45	6.71	32.66	37.00	4.34

*** Above 1 GHz**

Temperature: 22.8 °C Humidity: 38.5 % R.H. Test Date: 10. 02. 2015 Tested by: Kang Hyeon, Kim

■ D-SUB Mode

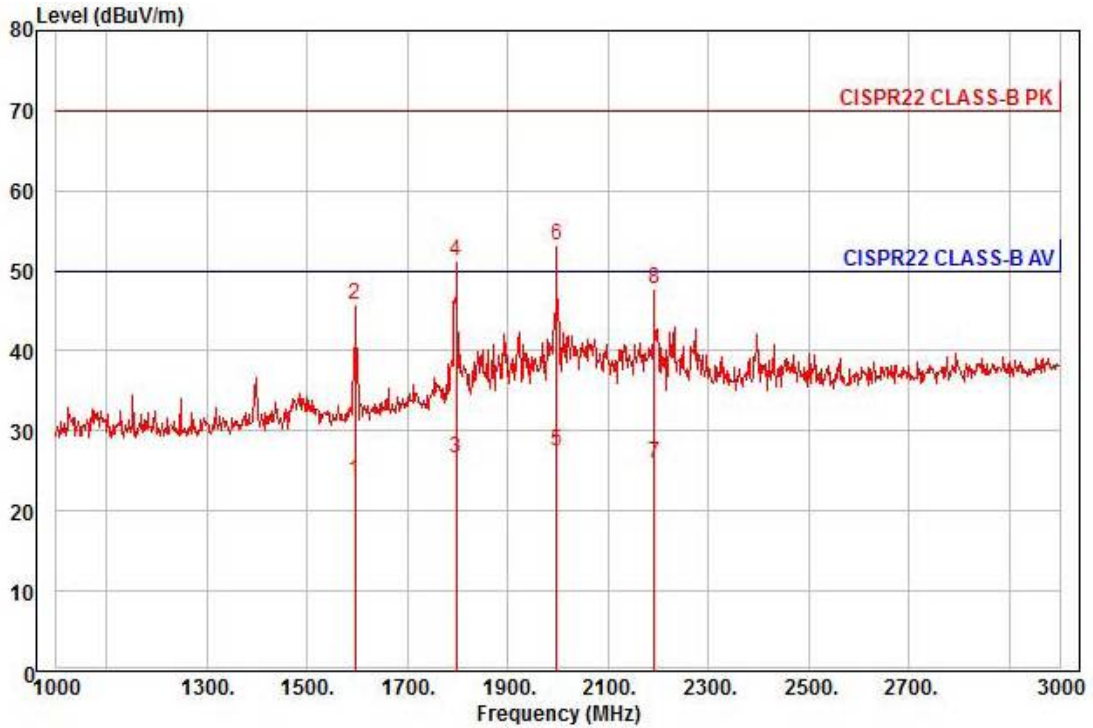

Site : chamber
 Condition: CISPR22 CLASS-B PK 3m HORN781(2015.05.07) horizontal
 : RBW:1000.000kHz VBW:1000.000kHz SWT:Auto
 Project : LCD MONITOR
 Model : SMT-2233
 Mode : D-SUB
 Memo : 230

	Read	Ant	Cable	Preamp	TPos	Limit	Over		
Freq	Level	Factor	Loss	Factor	deg	Line	Limit	Pol/Phase	Remark
MHz	dBuV	dB/m	dB	dB	deg	dBuV/m	dB		
1	1596.00	29.62	26.28	7.76	39.88	157	50.00	-26.22	horizontal Average
2	1596.00	51.56	26.28	7.76	39.88	157	70.00	-24.28	horizontal Peak
3	1798.00	30.88	27.08	8.34	39.79	131	50.00	-23.49	horizontal Average
4	1798.00	55.61	27.08	8.34	39.79	131	70.00	-18.76	horizontal Peak
5 av	1998.00	30.38	27.87	8.91	39.70	114	50.00	-22.54	horizontal Average
6 pp	1998.00	56.09	27.87	8.91	39.70	114	70.00	-16.83	horizontal Peak
7	2192.00	27.95	28.35	9.45	39.76	117	50.00	-24.01	horizontal Average
8	2192.00	49.72	28.35	9.45	39.76	117	70.00	-22.24	horizontal Peak

This report shall not be reproduced except in full, without the written approval of KES Co., Ltd.
 The test results in the report only apply to the tested sample.

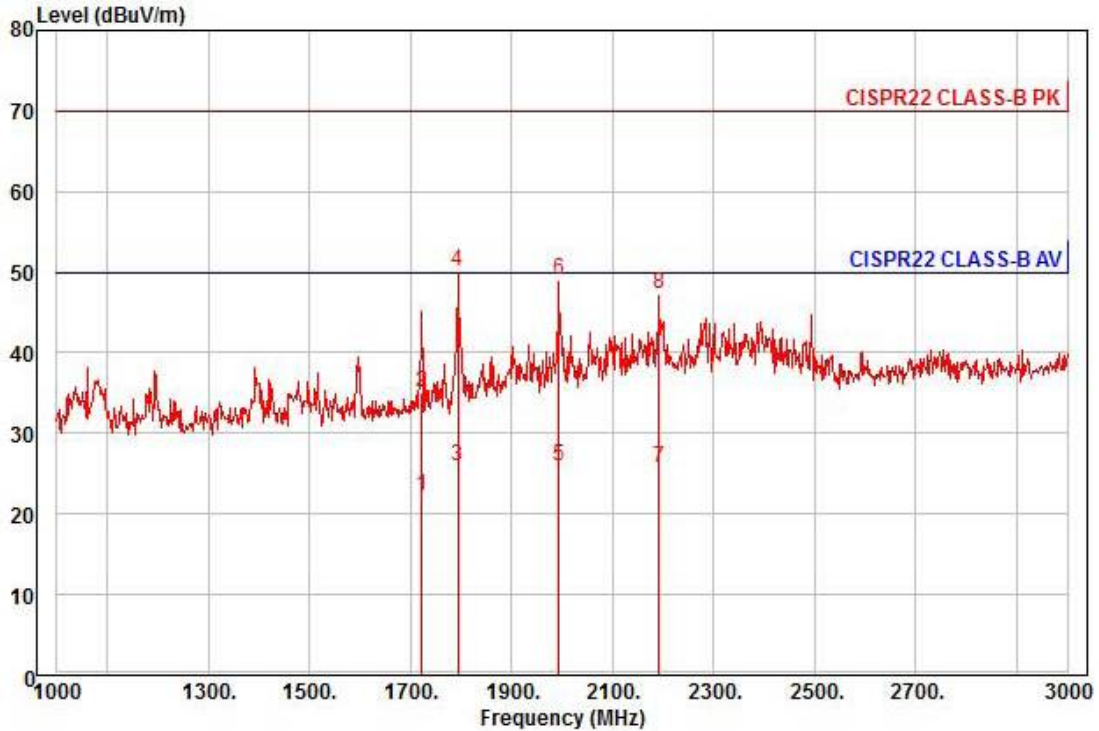

Site : chamber
 Condition: CISPR22 CLASS-B PK 3m HORN781(2015.05.07) vertical
 : RBW:1000.000kHz VBW:1000.000kHz SWT:Auto
 Project : LCD MONITOR
 Model : SMT-2233
 Mode : D-SUB
 Memo : 230

	Freq	Read Level	Ant Factor	Cable Loss	Preamp Factor	TPos	Limit Line	Over Limit	Pol/Phase	Remark
	MHz	dBuV	dB/m	dB	dB	deg	dBuV/m	dB		
1	1722.00	27.23	26.78	8.12	39.83	44	50.00	-27.70	vertical	Average
2	1722.00	40.11	26.78	8.12	39.83	44	70.00	-34.82	vertical	Peak
3 av	1794.00	30.27	27.06	8.33	39.79	136	50.00	-24.13	vertical	Average
4 pp	1794.00	54.56	27.06	8.33	39.79	136	70.00	-19.84	vertical	Peak
5	1994.00	28.78	27.86	8.90	39.70	174	50.00	-24.16	vertical	Average
6	1994.00	52.05	27.86	8.90	39.70	174	70.00	-20.89	vertical	Peak
7	2192.00	27.71	28.35	9.45	39.76	85	50.00	-24.25	vertical	Average
8	2192.00	49.22	28.35	9.45	39.76	85	70.00	-22.74	vertical	Peak

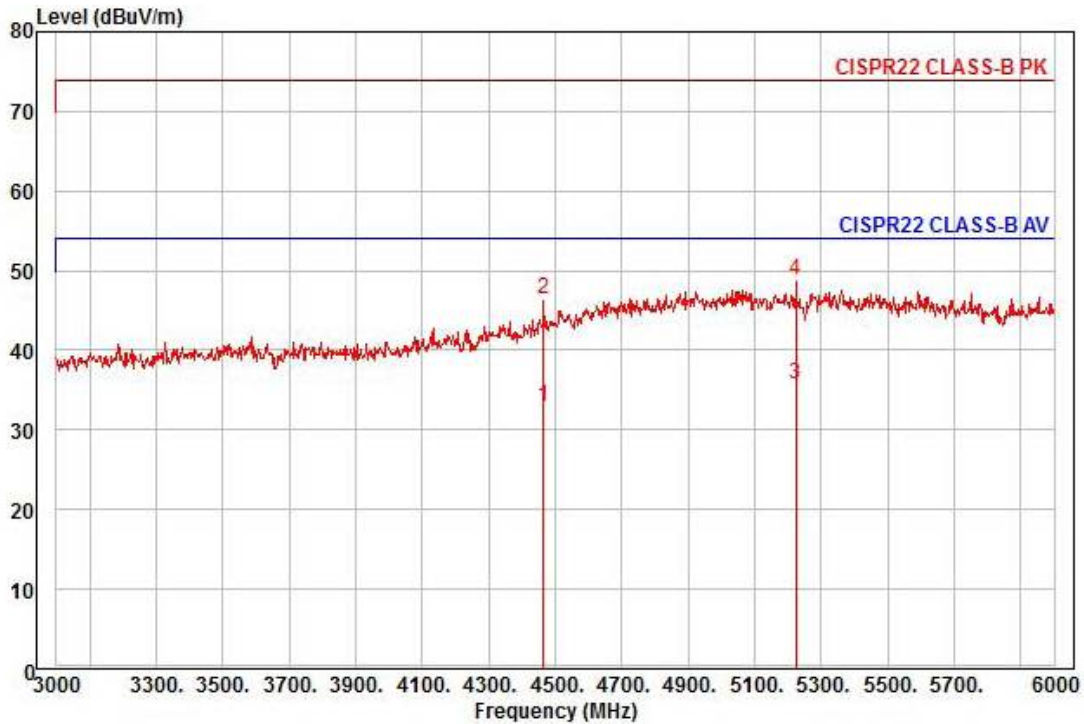

Site : chamber
 Condition: CISPR22 CLASS-B PK 3m HORN781(2015.05.07) horizontal
 : RBW:1000.000kHz VBW:1000.000kHz SWT:Auto
 Project : LCD MONITOR
 Model : SMT-2233
 Mode : D-SUB
 Memo : 230

	Read Freq	Read Level	Ant Factor	Cable Loss	Preamp Factor	TPos	Limit Line	Over Limit	Pol/Phase	Remark
	MHz	dBuV	dB/m	dB	dB	deg	dBuV/m	dB		
1	4464.00	24.80	34.66	13.88	40.38	226	54.00	-21.04	horizontal	Average
2	4464.00	38.20	34.66	13.88	40.38	226	74.00	-27.64	horizontal	Peak
3 pp	5223.00	23.44	37.27	15.28	40.18	180	54.00	-18.19	horizontal	Average
4 pk	5223.00	36.47	37.27	15.28	40.18	180	74.00	-25.16	horizontal	Peak

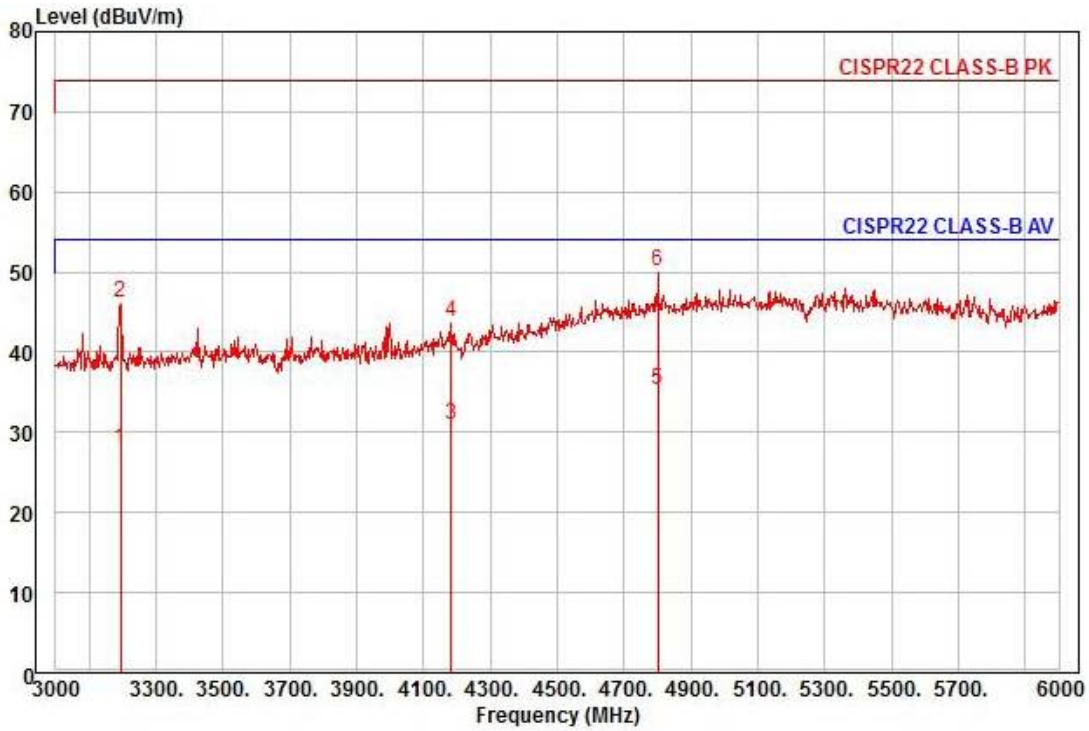

Site : chamber
 Condition: CISPR22 CLASS-B PK 3m HORN781(2015.05.07) vertical
 : RBW:1000.000kHz VBW:1000.000kHz SWT:Auto
 Project : LCD MONITOR
 Model : SMT-2233
 Mode : D-SUB
 Memo : 230

	Read Freq	Ant Level	Cable Factor	Preamp Loss	TPos	Limit Line	Over Limit	Pol/Phase	Remark
	MHz	dBuV	dB/m	dB	deg	dBuV/m	dB		
1	3195.00	25.35	30.66	11.96	40.11	314	54.00	-26.14	vertical Average
2	3195.00	43.64	30.66	11.96	40.11	314	74.00	-27.85	vertical Peak
3	4182.00	25.14	33.05	13.36	40.51	50	54.00	-22.96	vertical Average
4	4182.00	38.02	33.05	13.36	40.51	50	74.00	-30.08	vertical Peak
5 pp	4800.00	24.41	36.58	14.50	40.22	42	54.00	-18.73	vertical Average
6 pk	4800.00	39.28	36.58	14.50	40.22	42	74.00	-23.86	vertical Peak

HDMI Mode

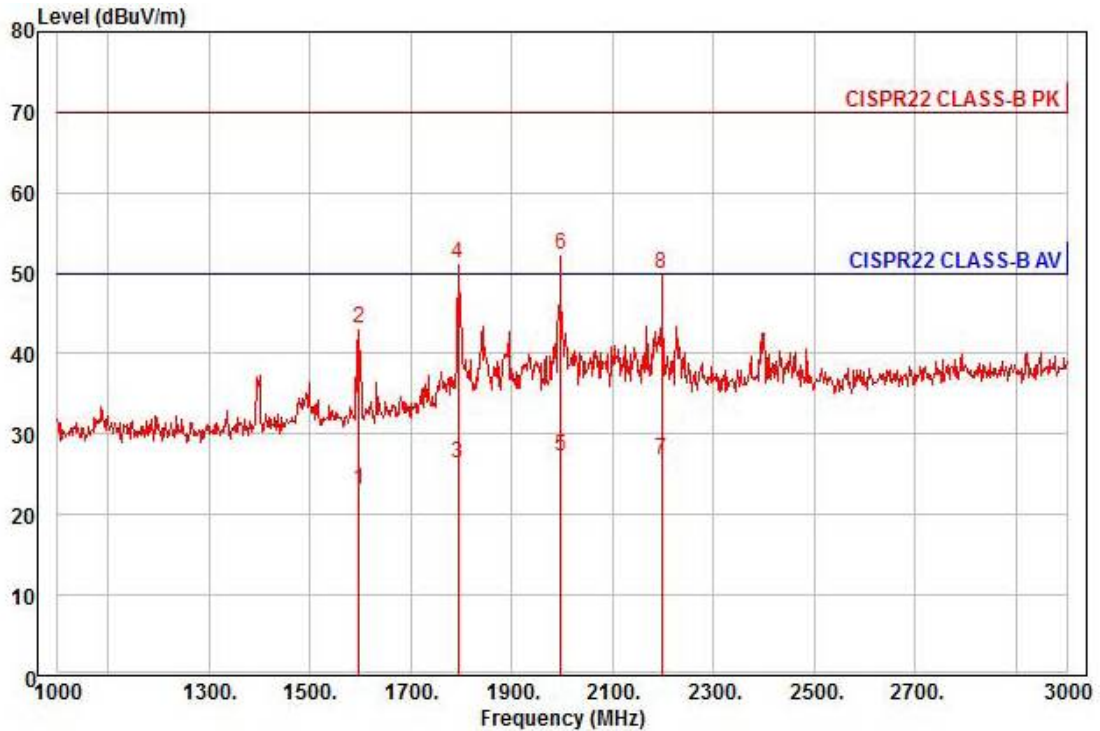

Site : chamber
 Condition: CISPR22 CLASS-B PK 3m HORN781(2015.05.07) horizontal
 : RBW:1000.000kHz VBW:1000.000kHz SWT:Auto
 Project : LCD MONITOR
 Model : SMT-2233
 Mode : HDMI
 Memo : 230

	Freq	Read Level	Ant Factor	Cable Loss	Preamp Factor	TPos	Limit Line	Over Limit	Pol/Phase	Remark
	MHz	dBuV	dB/m	dB	dB	deg	dBuV/m	dB		
1	1598.00	28.86	26.28	7.77	39.88	154	50.00	-26.97	horizontal	Average
2	1598.00	49.07	26.28	7.77	39.88	154	70.00	-26.76	horizontal	Peak
3	1794.00	30.73	27.06	8.33	39.79	76	50.00	-23.67	horizontal	Average
4	1794.00	55.56	27.06	8.33	39.79	76	70.00	-18.84	horizontal	Peak
5 av	1998.00	30.12	27.87	8.91	39.70	84	50.00	-22.80	horizontal	Average
6 pp	1998.00	55.22	27.87	8.91	39.70	84	70.00	-17.70	horizontal	Peak
7	2198.00	28.64	28.37	9.47	39.76	76	50.00	-23.28	horizontal	Average
8	2198.00	51.88	28.37	9.47	39.76	76	70.00	-20.04	horizontal	Peak

This report shall not be reproduced except in full, without the written approval of KES Co., Ltd.
 The test results in the report only apply to the tested sample.

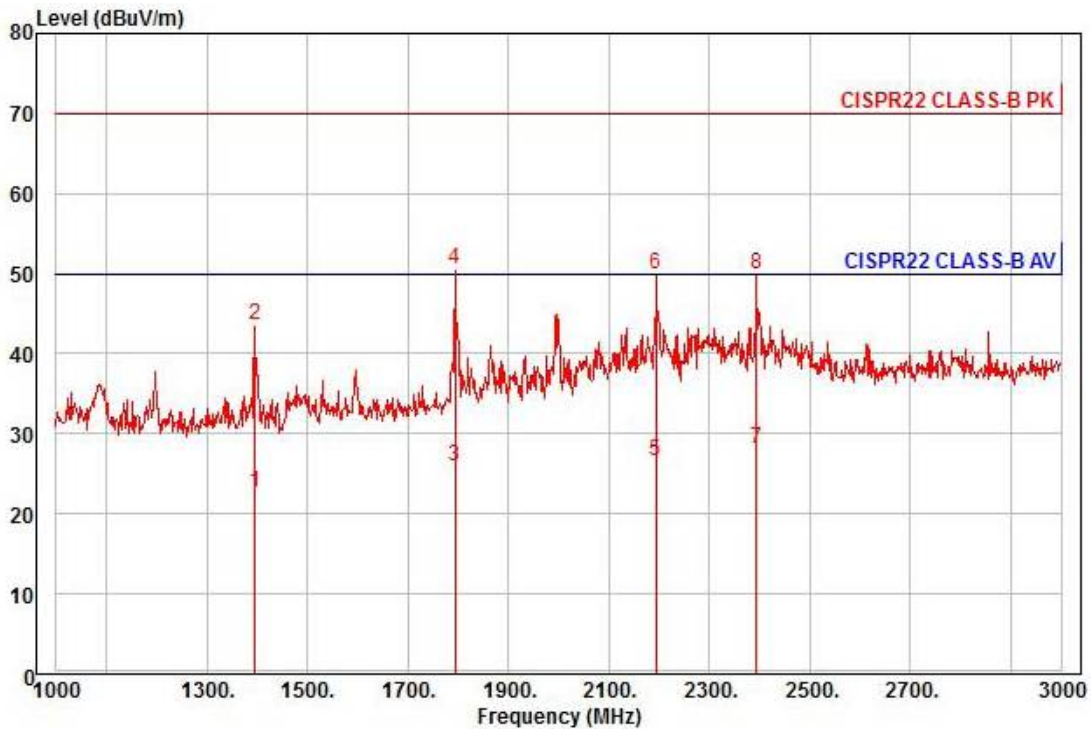

Site : chamber
 Condition: CISPR22 CLASS-B PK 3m HORN781(2015.05.07) vertical
 : RBW:1000.000kHz VBW:1000.000kHz SWT:Auto
 Project : LCD MONITOR
 Model : SMT-2233
 Mode : HDMI
 Memo : 230

	Read Freq	Ant Level	Ant Factor	Cable Loss	Preamp Factor	TPos	Limit Line	Over Limit	Pol/Phase	Remark
	MHz	dBuV	dB/m	dB	dB	deg	dBuV/m	dB		
1	1396.00	30.05	25.48	7.19	39.97	51	50.00	-27.25	vertical	Average
2	1396.00	50.90	25.48	7.19	39.97	51	70.00	-26.40	vertical	Peak
3	1794.00	30.40	27.06	8.33	39.79	69	50.00	-24.00	vertical	Average
4 pp	1794.00	55.02	27.06	8.33	39.79	69	70.00	-19.38	vertical	Peak
5	2194.00	28.50	28.36	9.46	39.76	147	50.00	-23.44	vertical	Average
6	2194.00	51.75	28.36	9.46	39.76	147	70.00	-20.19	vertical	Peak
7 av	2394.00	28.99	28.85	10.02	39.81	359	50.00	-21.95	vertical	Average
8	2394.00	50.79	28.85	10.02	39.81	359	70.00	-20.15	vertical	Peak

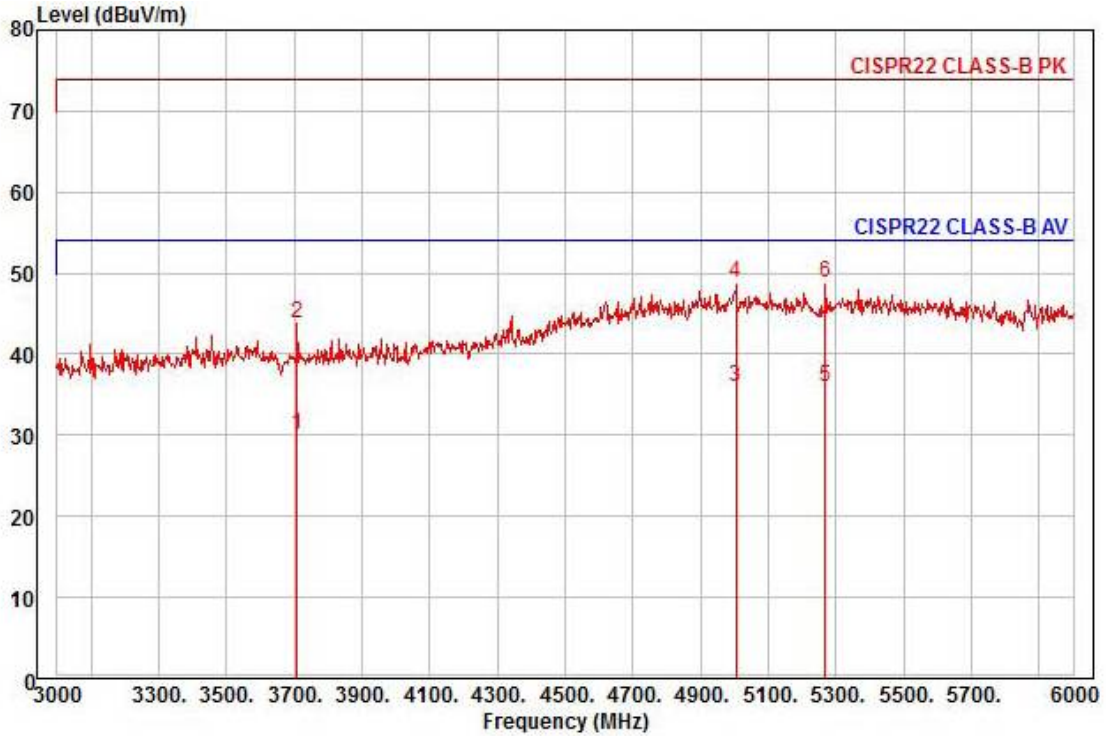

Site : chamber
 Condition: CISPR22 CLASS-B PK 3m HORN781(2015.05.07) horizontal
 : RBW:1000.000kHz VBW:1000.000kHz SWT:Auto
 Project : LCD MONITOR
 Model : SMT-2233
 Mode : HDMI
 Memo : 230

	Read Freq	Ant Level	Cable Factor	Preamp Loss	TPos	Limit Line	Over Limit	Pol/Phase	Remark
	MHz	dBuV	dB/m	dB	deg	dBuV/m	dB		
1	3708.00	26.24	31.52	12.64	40.42	174	54.00	-24.02	horizontal Average
2	3708.00	40.00	31.52	12.64	40.42	174	74.00	-30.26	horizontal Peak
3 pp	5004.00	23.60	37.71	14.88	40.12	160	54.00	-17.93	horizontal Average
4 pk	5004.00	36.46	37.71	14.88	40.12	160	74.00	-25.07	horizontal Peak
5	5268.00	23.63	37.18	15.36	40.19	64	54.00	-18.02	horizontal Average
6	5268.00	36.43	37.18	15.36	40.19	64	74.00	-25.22	horizontal Peak

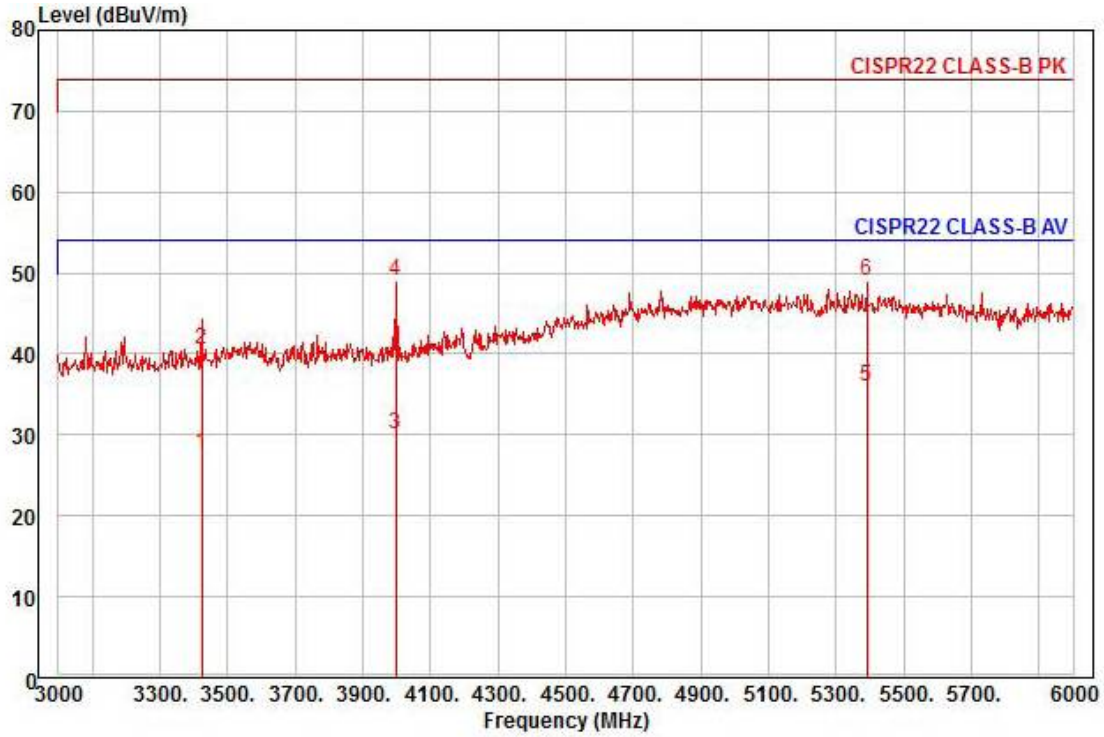

Site : chamber
 Condition: CISPR22 CLASS-B PK 3m HORN781(2015.05.07) vertical
 : RBW:1000.000kHz VBW:1000.000kHz SWT:Auto
 Project : LCD MONITOR
 Model : SMT-2233
 Mode : HDMI
 Memo : 230

	Read Freq	Level	Ant Factor	Cable Loss	Preamp Factor	TPos	Limit Line	Over Limit	Pol/Phase	Remark
	MHz	dBuV	dB/m	dB	dB	deg	dBuV/m	dB		
1	3423.00	24.63	31.04	12.26	40.25	157	54.00	-26.32	vertical	Average
2	3423.00	37.56	31.04	12.26	40.25	157	74.00	-33.39	vertical	Peak
3	3999.00	25.65	32.01	13.03	40.60	163	54.00	-23.91	vertical	Average
4 pk	3999.00	44.68	32.01	13.03	40.60	163	74.00	-24.88	vertical	Peak
5 pp	5391.00	23.58	36.93	15.58	40.22	282	54.00	-18.13	vertical	Average
6	5391.00	36.68	36.93	15.58	40.22	282	74.00	-25.03	vertical	Peak

■ Video Mode

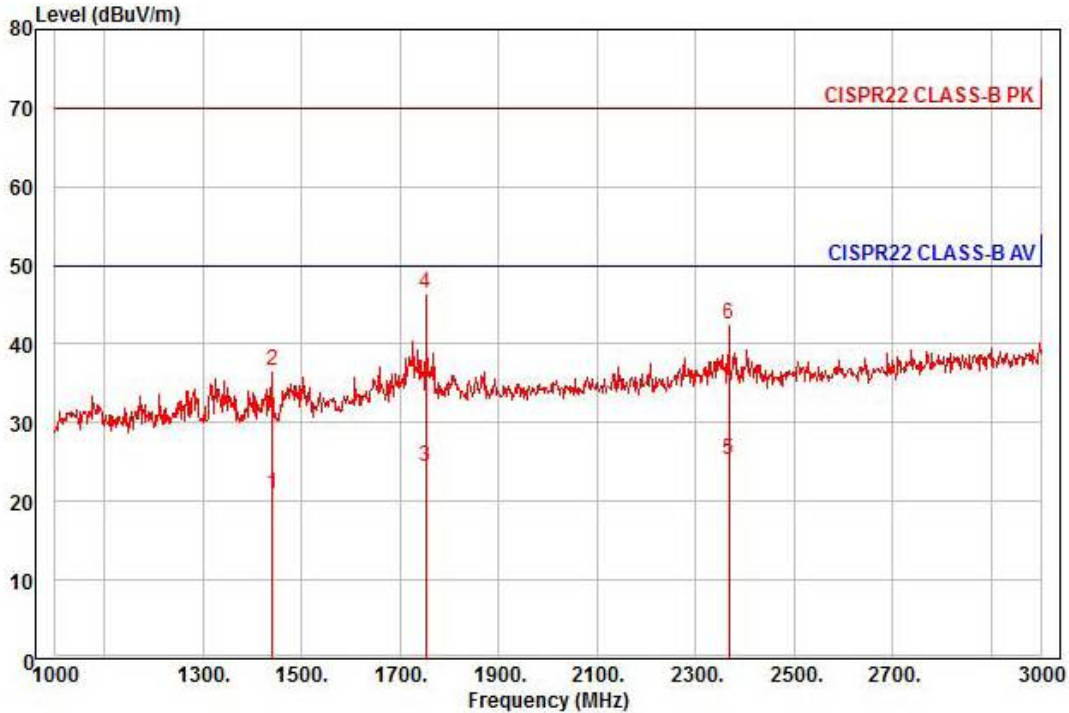

Site : chamber
 Condition: CISPR22 CLASS-B PK 3m HORN781(2015.05.07) horizontal
 : RBW:1000.000kHz VBW:1000.000kHz SWT:Auto
 Project : LCD MONITOR
 Model : SMT-2233
 Mode : video
 Memo : 230

	Read Freq	Ant Level	Ant Factor	Cable Loss	Preamp Factor	TPos	Limit Line	Over Limit	Pol/Phase	Remark
	MHz	dBuV	dB/m	dB	dB	deg	dBuV/m	dB		
1	1440.00	27.99	25.66	7.31	39.95	40	50.00	-28.99	horizontal	Average
2	1440.00	43.65	25.66	7.31	39.95	40	70.00	-33.33	horizontal	Peak
3	1752.00	29.03	26.90	8.21	39.81	10	50.00	-25.67	horizontal	Average
4 pp	1752.00	51.12	26.90	8.21	39.81	10	70.00	-23.58	horizontal	Peak
5 av	2368.00	26.32	28.78	9.94	39.81	40	50.00	-24.77	horizontal	Average
6	2368.00	43.58	28.78	9.94	39.81	40	70.00	-27.51	horizontal	Peak

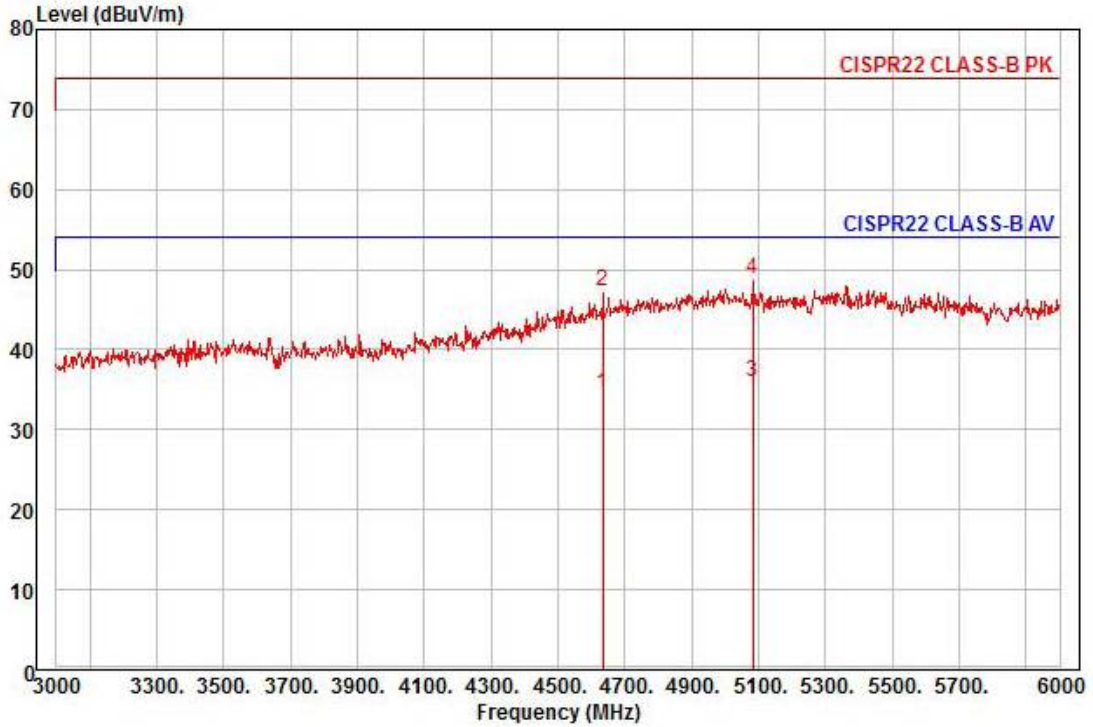

Site : chamber
 Condition: CISPR22 CLASS-B PK 3m HORN781(2015.05.07) horizontal
 : RBW:1000.000kHz VBW:1000.000kHz SWT:Auto
 Project : LCD MONITOR
 Model : SMT-2233
 Mode : video
 Memo : 230

	Read Freq	Ant Level	Ant Factor	Cable Loss	Preamp Factor	TPos	Limit Line	Over Limit	Pol/Phase	Remark
	MHz	dBuV	dB/m	dB	dB	deg	dBuV/m	dB		
1	4635.00	24.82	35.64	14.20	40.30	259	54.00	-19.64	horizontal	Average
2	4635.00	37.68	35.64	14.20	40.30	259	74.00	-26.78	horizontal	Peak
3 pp	5082.00	23.51	37.55	15.02	40.14	268	54.00	-18.06	horizontal	Average
4 pk	5082.00	36.35	37.55	15.02	40.14	268	74.00	-25.22	horizontal	Peak

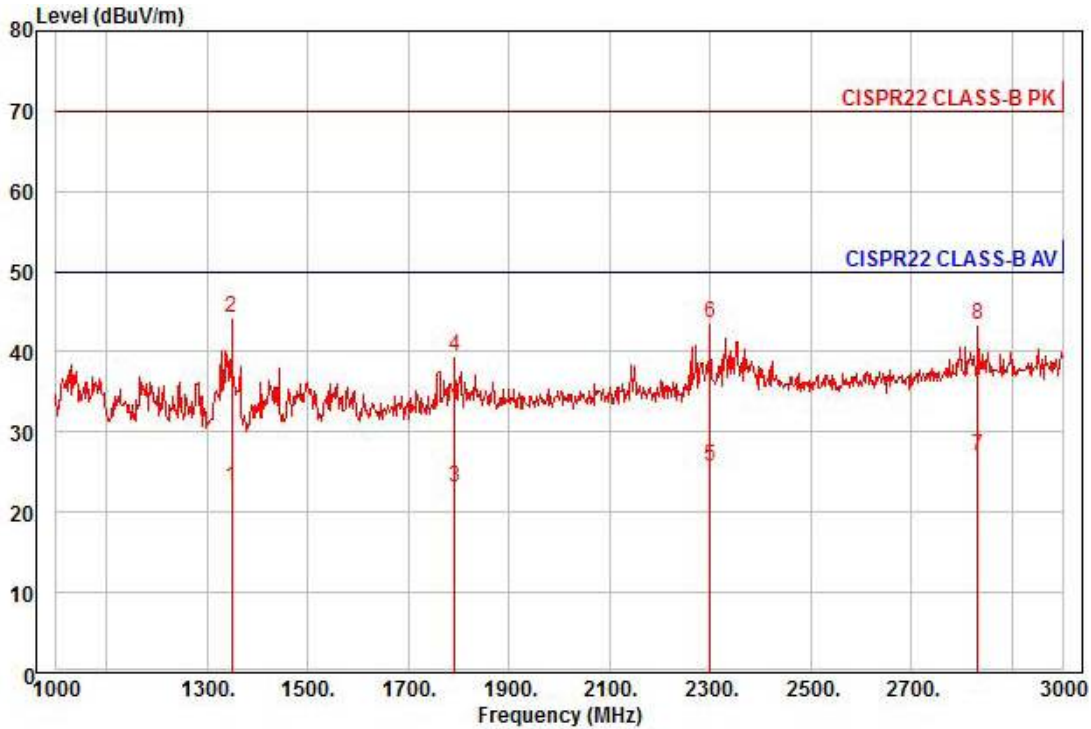

Site : chamber
 Condition: CISPR22 CLASS-B PK 3m HORN781(2015.05.07) vertical
 : RBW:1000.000kHz VBW:1000.000kHz SWT:Auto
 Project : LCD MONITOR
 Model : SMT-2233
 Mode : video
 Memo : 230

	Freq	Read Level	Ant Factor	Cable Loss	Preamp Factor	TPos	Limit Line	Over Limit	Pol/Phase	Remark
	MHz	dBuV	dB/m	dB	dB	deg	dBuV/m	dB		
1	1348.00	30.75	25.29	7.05	39.99	16	50.00	-26.90	vertical	Average
2 pk	1348.00	51.83	25.29	7.05	39.99	16	70.00	-25.82	vertical	Peak
3	1792.00	27.55	27.05	8.32	39.79	22	50.00	-26.87	vertical	Average
4	1792.00	43.84	27.05	8.32	39.79	22	70.00	-30.58	vertical	Peak
5	2300.00	27.10	28.61	9.75	39.79	360	50.00	-24.33	vertical	Average
6	2300.00	45.00	28.61	9.75	39.79	360	70.00	-26.43	vertical	Peak
7 pp	2832.00	25.79	29.92	11.23	39.94	16	50.00	-23.00	vertical	Average
8	2832.00	42.06	29.92	11.23	39.94	16	70.00	-26.73	vertical	Peak

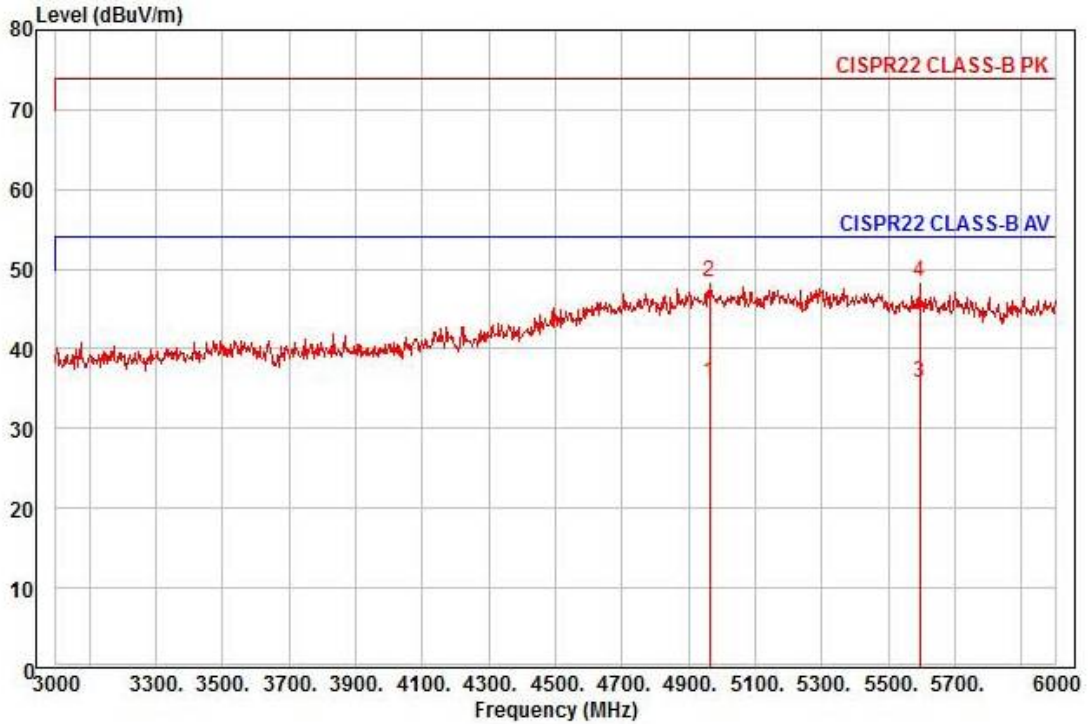

Site : chamber
 Condition: CISPR22 CLASS-B PK 3m HORN781(2015.05.07) vertical
 : RBW:1000.000kHz VBW:1000.000kHz SWT:Auto
 Project : LCD MONITOR
 Model : SMT-2233
 Mode : video
 Memo : 230

	Freq	Read Level	Ant Factor	Cable Loss	Preamp Factor	TPos	Limit Line	Over Limit	Pol/Phase	Remark
	MHz	dBuV	dB/m	dB	dB	deg	dBuV/m	dB		
1 pp	4962.00	23.58	37.50	14.80	40.14	307	54.00	-18.26	vertical	Average
2	4962.00	36.21	37.50	14.80	40.14	307	74.00	-25.63	vertical	Peak
3	5595.00	23.52	36.52	15.95	40.27	259	54.00	-18.28	vertical	Average
4 pk	5595.00	36.25	36.52	15.95	40.27	259	74.00	-25.55	vertical	Peak

5.3 Harmonics / Voltage Fluctuations Measurements

5.3.1 Test Description

Harmonics of the fundamental current were measured up to 2 kHz using a universal power analyzer. The measurements were carried out under steady conditions and using averaging.

Before making measurements the class of the E.U.T has been evaluated, it is necessary for the E.U.T to decide which class the E.U.T fulfills into; A, B, C or D

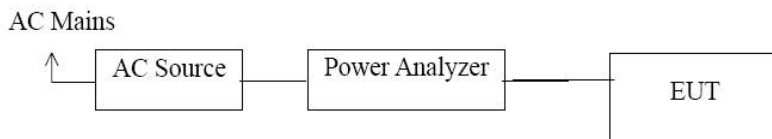

5.3.2 Test Equipments

Description	Manufacturer	Model Number	Serial Number	Cal. Due
AC Source	EM test	ACS 500 N	V1024106760	08. 13. 2016
Digital Power Analyzer	EM test	DPA 500 N	V1024106759	08. 13. 2016

5.3.3 Test Environments

Ambient Temperatures : 22.6 °C
 Relative Humidity : 43.5 % R.H.

5.3.4 Test Procedures

The E.U.T was installed and placed on a non-conductive table and was connected to the AC power source, 230 V (ac), 50 Hz via the measuring equipment with its attached AC power cord. All other equipment or peripherals included in the test, and having a separate power supply, are connected to the outlet, supplying 230 V (ac), 50 Hz. A typical configuration is defined in the specification ANSI 63.4 or CISPR22. This ensures the repeatability of the test.

The E.U.T is set in operation and was monitored for measurements with the software, supplied by test equipment manufacturer. An EMC test program provided by client was used to exercise the E.U.T.



5.3.5 Test Results

Harmonic test is not applicable.

According to the data in section 5.6.6 and 5.3.7, the EUT complied with the EN61000-3-2:2006 and EN61000-3-3:2008 standards, and detailed test results are found in the following test data.

5.3.6 Test Data - Homonic

Test Date: 10. 05. 2015

Tested by: Kang Hyeon, Kim

■ D-SUB Mode

Average harmonic current results

Hn	Ieff [A]	% of Limit	Limit [A]	Result
1	94.095E-3			
2	2.137E-3			PASS
3	87.327E-3	4.219	2.07	PASS
4	1.932E-3			PASS
5	83.330E-3	8.122	1.03	PASS
6	2.658E-3			PASS
7	78.207E-3	11.285	693.00E-3	PASS
8	1.833E-3			PASS
9	72.127E-3	20.035	360.00E-3	PASS
10	1.834E-3			PASS
11	64.719E-3	21.791	297.00E-3	PASS
12	1.641E-3			PASS
13	56.317E-3	29.797	189.00E-3	PASS
14	1.351E-3			PASS
15	47.418E-3	35.125	135.00E-3	PASS
16	1.092E-3			PASS
17	38.840E-3	32.608	119.11E-3	PASS
18	954.482E-6			PASS
19	30.486E-3	28.604	106.58E-3	PASS
20	910.242E-6			PASS
21	22.549E-3	23.385	96.43E-3	PASS
22	914.185E-6			PASS
23	15.683E-3	17.812	88.05E-3	PASS
24	863.456E-6			PASS
25	9.828E-3	12.133	81.00E-3	PASS
26	890.356E-6			PASS
27	5.899E-3	7.866	75.00E-3	PASS
28	824.908E-6			PASS
29	4.420E-3			PASS
30	856.385E-6			PASS
31	5.560E-3	8.511	65.32E-3	PASS
32	803.463E-6			PASS
33	6.615E-3	10.781	61.36E-3	PASS
34	755.176E-6			PASS
35	7.195E-3	12.435	57.86E-3	PASS
36	737.339E-6			PASS
37	7.088E-3	12.951	54.73E-3	PASS
38	705.333E-6			PASS
39	6.256E-3	12.050	51.92E-3	PASS
40	738.028E-6			PASS

Harmonic currents less than 0.6% of the input current measured under the test conditions, or less than 5 mA, whichever is greater, are disregarded



Test Data - Harmonics (continued)

<i>Maximum harmonic voltage results</i>				
Hn	Ieff [A]	Ueff [%]	Limit [%]	Result
1	94.567E-3			
2	2.680E-3			PASS
3	87.625E-3	1.905	4.60	PASS
4	3.074E-3			PASS
5	84.073E-3	3.687	2.28	PASS
6	3.340E-3			PASS
7	79.279E-3	5.148	1.54	PASS
8	2.195E-3			PASS
9	72.548E-3	9.069	800.00E-3	PASS
10	2.493E-3			PASS
11	65.206E-3	9.880	660.00E-3	PASS
12	1.985E-3			PASS
13	56.615E-3	13.480	420.00E-3	PASS
14	1.590E-3			PASS
15	47.681E-3	15.894	300.00E-3	PASS
16	1.464E-3			PASS
17	39.213E-3	14.814	264.70E-3	PASS
18	1.175E-3			PASS
19	30.693E-3	12.959	236.84E-3	PASS
20	1.058E-3			PASS
21	22.890E-3	10.682	214.28E-3	PASS
22	1.134E-3			PASS
23	16.006E-3	8.181	195.66E-3	PASS
24	1.007E-3			PASS
25	10.015E-3	5.564	180.00E-3	PASS
26	1.049E-3			PASS
27	6.074E-3	3.644	166.66E-3	PASS
28	907.298E-6			PASS
29	4.646E-3			PASS
30	1.028E-3			PASS
31	5.758E-3	3.967	145.16E-3	PASS
32	957.936E-6			PASS
33	6.770E-3	4.965	136.36E-3	PASS
34	928.337E-6			PASS
35	7.379E-3	5.739	128.58E-3	PASS
36	873.375E-6			PASS
37	7.256E-3	5.966	121.62E-3	PASS
38	884.490E-6			PASS
39	6.516E-3	5.647	115.38E-3	PASS
40	903.519E-6			PASS

Harmonic currents less than 0.6% of the input current measured under the test conditions, or less than 5 mA, whichever is greater, are disregarded



■ HDMI Mode

Average harmonic current results

Hn	Ieff [A]	% of Limit	Limit [A]	Result
1	91.947E-3			
2	2.210E-3			PASS
3	85.632E-3	4.137	2.07	PASS
4	2.068E-3			PASS
5	81.176E-3	7.912	1.03	PASS
6	2.760E-3			PASS
7	76.145E-3	10.988	693.00E-3	PASS
8	1.937E-3			PASS
9	70.910E-3	19.697	360.00E-3	PASS
10	1.819E-3			PASS
11	63.822E-3	21.489	297.00E-3	PASS
12	1.713E-3			PASS
13	55.410E-3	29.317	189.00E-3	PASS
14	1.443E-3			PASS
15	46.392E-3	34.364	135.00E-3	PASS
16	1.108E-3			PASS
17	37.870E-3	31.793	119.11E-3	PASS
18	994.934E-6			PASS
19	29.890E-3	28.045	106.58E-3	PASS
20	978.006E-6			PASS
21	22.268E-3	23.094	96.43E-3	PASS
22	1.013E-3			PASS
23	15.539E-3	17.649	88.05E-3	PASS
24	943.710E-6			PASS
25	9.686E-3	11.958	81.00E-3	PASS
26	962.495E-6			PASS
27	5.785E-3	7.714	75.00E-3	PASS
28	898.772E-6			PASS
29	4.398E-3			PASS
30	921.437E-6			PASS
31	5.449E-3	8.342	65.32E-3	PASS
32	840.457E-6			PASS
33	6.516E-3	10.620	61.36E-3	PASS
34	782.448E-6			PASS
35	6.997E-3	12.093	57.86E-3	PASS
36	786.137E-6			PASS
37	6.926E-3	12.655	54.73E-3	PASS
38	701.989E-6			PASS
39	6.090E-3	11.729	51.92E-3	PASS
40	752.833E-6			PASS

Harmonic currents less than 0.6% of the input current measured under the test conditions, or less than 5 mA, whichever is greater, are disregarded



Test Data - Harmonics (continued)

<i>Maximum harmonic voltage results</i>				
Hn	Ieff [A]	Ueff [%]	Limit [%]	Result
1	95.088E-3			
2	2.723E-3			PASS
3	88.778E-3	1.930	4.60	PASS
4	2.896E-3			PASS
5	84.063E-3	3.687	2.28	PASS
6	3.247E-3			PASS
7	78.720E-3	5.112	1.54	PASS
8	2.569E-3			PASS
9	73.118E-3	9.140	800.00E-3	PASS
10	2.451E-3			PASS
11	65.614E-3	9.941	660.00E-3	PASS
12	2.221E-3			PASS
13	56.795E-3	13.523	420.00E-3	PASS
14	1.922E-3			PASS
15	47.273E-3	15.758	300.00E-3	PASS
16	1.520E-3			PASS
17	38.373E-3	14.497	264.70E-3	PASS
18	1.416E-3			PASS
19	30.131E-3	12.722	236.84E-3	PASS
20	1.270E-3			PASS
21	22.569E-3	10.533	214.28E-3	PASS
22	1.278E-3			PASS
23	15.938E-3	8.146	195.66E-3	PASS
24	1.242E-3			PASS
25	10.119E-3	5.622	180.00E-3	PASS
26	1.142E-3			PASS
27	6.001E-3	3.601	166.66E-3	PASS
28	1.113E-3			PASS
29	4.777E-3			PASS
30	1.128E-3			PASS
31	5.992E-3	4.128	145.16E-3	PASS
32	1.055E-3			PASS
33	7.066E-3	5.182	136.36E-3	PASS
34	957.702E-6			PASS
35	7.376E-3	5.736	128.58E-3	PASS
36	917.897E-6			PASS
37	7.160E-3	5.887	121.62E-3	PASS
38	851.486E-6			PASS
39	6.209E-3	5.381	115.38E-3	PASS
40	896.032E-6			PASS

Harmonic currents less than 0.6% of the input current measured under the test conditions, or less than 5 mA, whichever is greater, are disregarded



Video Mode

Average harmonic current results

Hn	Ieff [A]	% of Limit	Limit [A]	Result
1	91.520E-3			
2	2.094E-3			PASS
3	84.551E-3	4.085	2.07	PASS
4	1.816E-3			PASS
5	80.966E-3	7.891	1.03	PASS
6	2.718E-3			PASS
7	76.047E-3	10.974	693.00E-3	PASS
8	1.790E-3			PASS
9	69.896E-3	19.416	360.00E-3	PASS
10	1.780E-3			PASS
11	62.732E-3	21.122	297.00E-3	PASS
12	1.574E-3			PASS
13	54.695E-3	28.939	189.00E-3	PASS
14	1.378E-3			PASS
15	46.296E-3	34.294	135.00E-3	PASS
16	1.131E-3			PASS
17	38.058E-3	31.951	119.11E-3	PASS
18	990.189E-6			PASS
19	29.875E-3	28.032	106.58E-3	PASS
20	850.778E-6			PASS
21	22.082E-3	22.900	96.43E-3	PASS
22	877.724E-6			PASS
23	15.438E-3	17.534	88.05E-3	PASS
24	866.345E-6			PASS
25	9.732E-3	12.015	81.00E-3	PASS
26	885.110E-6			PASS
27	5.786E-3	7.716	75.00E-3	PASS
28	819.404E-6			PASS
29	4.134E-3			PASS
30	898.871E-6			PASS
31	5.236E-3	8.016	65.32E-3	PASS
32	845.914E-6			PASS
33	6.308E-3	10.280	61.36E-3	PASS
34	781.667E-6			PASS
35	6.966E-3	12.040	57.86E-3	PASS
36	779.323E-6			PASS
37	6.927E-3	12.657	54.73E-3	PASS
38	741.457E-6			PASS
39	6.214E-3	11.968	51.92E-3	PASS
40	775.148E-6			PASS

Harmonic currents less than 0.6% of the input current measured under the test conditions, or less than 5 mA, whichever is greater, are disregarded



Test Data - Harmonics (continued)

<i>Maximum harmonic voltage results</i>				
Hn	Ieff [A]	Ueff [%]	Limit [%]	Result
1	92.004E-3			
2	2.529E-3			PASS
3	84.977E-3	1.847	4.60	PASS
4	2.954E-3			PASS
5	81.690E-3	3.583	2.28	PASS
6	3.359E-3			PASS
7	77.072E-3	5.005	1.54	PASS
8	2.057E-3			PASS
9	70.510E-3	8.814	800.00E-3	PASS
10	2.342E-3			PASS
11	63.481E-3	9.618	660.00E-3	PASS
12	2.009E-3			PASS
13	55.154E-3	13.132	420.00E-3	PASS
14	1.581E-3			PASS
15	46.722E-3	15.574	300.00E-3	PASS
16	1.439E-3			PASS
17	38.662E-3	14.606	264.70E-3	PASS
18	1.197E-3			PASS
19	30.434E-3	12.850	236.84E-3	PASS
20	1.035E-3			PASS
21	22.692E-3	10.590	214.28E-3	PASS
22	1.118E-3			PASS
23	16.123E-3	8.240	195.66E-3	PASS
24	1.011E-3			PASS
25	10.334E-3	5.741	180.00E-3	PASS
26	1.112E-3			PASS
27	6.271E-3	3.763	166.66E-3	PASS
28	943.377E-6			PASS
29	4.406E-3			PASS
30	1.064E-3			PASS
31	5.707E-3	3.932	145.16E-3	PASS
32	963.478E-6			PASS
33	6.704E-3	4.916	136.36E-3	PASS
34	884.588E-6			PASS
35	7.177E-3	5.581	128.58E-3	PASS
36	896.070E-6			PASS
37	7.047E-3	5.795	121.62E-3	PASS
38	906.282E-6			PASS
39	6.457E-3	5.596	115.38E-3	PASS
40	929.503E-6			PASS

Harmonic currents less than 0.6% of the input current measured under the test conditions, or less than 5 mA, whichever is greater, are disregarded

5.3.7 Test Data - Voltage Fluctuations

■ D-SUB Mode

Maximum Flicker results

	E.U.T values	Limit	Result
Pst	0.028	1.00	PASS
Plt	0.028	0.65	PASS
dc [%]	0.000	3.30	PASS
dmax [%]	0.046	4.00	PASS
dt [s]	0.000	0.50	PASS

■ HDMI Mode

Maximum Flicker results

	E.U.T values	Limit	Result
Pst	0.035	1.00	PASS
Plt	0.035	0.65	PASS
dc [%]	0.000	3.30	PASS
dmax [%]	0.186	4.00	PASS
dt [s]	0.000	0.50	PASS



■ Video Mode

Maximum Flicker results

	E.U.T values	Limit	Result
Pst	0.033	1.00	PASS
Plt	0.033	0.65	PASS
dc [%]	0.000	3.30	PASS
dmax [%]	0.186	4.00	PASS
dt [s]	0.000	0.50	PASS

5.4 Electrostatic Discharge Immunity

5.4.1 Test Description

The E.U.T and all local support equipment were placed on non-metallic support 0.8 m above a reference ground plane (RGP) and was put into operation according to the specified operating mode.

5.4.2 Test Equipments

Description	Manufacturer	Model Number	Serial Number	Cal. Due
ESD SIMULATOR	Noise Ken	ESS-2000	ESS05X4620	06. 30. 2016

5.4.3 Test Environment

Ambient Temperatures :	15 °C ~ 35 °C
Relative Humidity :	25 % R.H. ~ 75 % R.H.
Atmospheric Pressure :	86.0 kPa ~ 106.0 kPa

5.4.4 Test Levels

Discharge Impedance :	330 Ω ± 10 % / 150 pF ± 10 %
Type of Discharge :	Direct - Air Discharge (± 2 kV & ± 4 kV & ± 8 kV), Contact Discharge (± 6 kV) Indirect - HCP Discharge (± 2 kV & ± 4 kV & ± 6 kV) VCP Discharge (± 2 kV & ± 4 kV & ± 6 kV)
Polarity of Output Voltage :	Positive and Negative
Discharge Repetition Rate :	1/sec
Number of Discharges :	more than 10 times
Performance Criteria :	B

5.4.5 Test Procedure

Test programs and software were chosen so as to exercise all normal modes of operation of the E.U.T. The use of special exercising software is encouraged, but permitted only where it can be shown that the E.U.T is being comprehensively exercised.

The test was conducted in the following order: Air Discharge, Direct Contact Discharge, Indirect Contact Horizontal Coupling Plane (HCP) Discharge, and Indirect Contact Vertical Coupling Plane (VCP) Discharge. The electrostatic discharge test levels were set and discharges for the different test modes were set appropriately. The electrostatic discharge is applied to the conductive surface of the E.U.T, and along all seams and control surfaces on the E.U.T. When a discharge occurs and an error is caused, the type of error, discharge level and location is recorded.

5.4.6 Test Results

According to the data in section 5.4.7, the E.U.T complied with the EN61000-4-2 standards, and detailed test results are found in the following test data.

5.4.7 Test Data

Temperature: 22.6 °C Humidity: 43.5 % R.H. Test Date: 10. 05. 2015 Tested by: Kang Hyeon, Kim

■ D-SUB Mode

Indirect Discharge

No.	Test Point	Discharge Method	Performance Results	Remarks
1	HCP Contact	Contact Discharge	A	-
2	VCP Contact	Contact Discharge	A	-

Direct Discharge

No.	Test Point	Discharge Method	Performance Results	Remarks
1	LCD	Air Discharge	A	-
2	Port	Air Discharge	A	-

■ HDMI Mode

Indirect Discharge

No.	Test Point	Discharge Method	Performance Results	Remarks
1	HCP Contact	Contact Discharge	A	-
2	VCP Contact	Contact Discharge	A	-

Direct Discharge

No.	Test Point	Discharge Method	Performance Results	Remarks
1	LCD	Air Discharge	A	-
2	Port	Air Discharge	A	-



■ Video Mode

Indirect Discharge

No.	Test Point	Discharge Method	Performance Results	Remarks
1	HCP Contact	Contact Discharge	A	-
2	VCP Contact	Contact Discharge	A	-

Direct Discharge

No.	Test Point	Discharge Method	Performance Results	Remarks
1	LCD	Air Discharge	A	-
2	Port	Contact Discharge	A	-

Performance Results

- A: Normal performance within the specification limits.
- B: Temporary degradation or loss of function or performance which is self-recoverable.
- C: Temporary degradation or loss of function or performance which requires operator intervention or system reset.

5.5 Radio-frequency electromagnetic field Amplitude modulated Immunity

5.5.1 Test Description

The E.U.T and all local support equipment were placed on a non-metallic support 0.8 m above a reference ground plane (RGP) and was put into operation according to the specified operating mode.

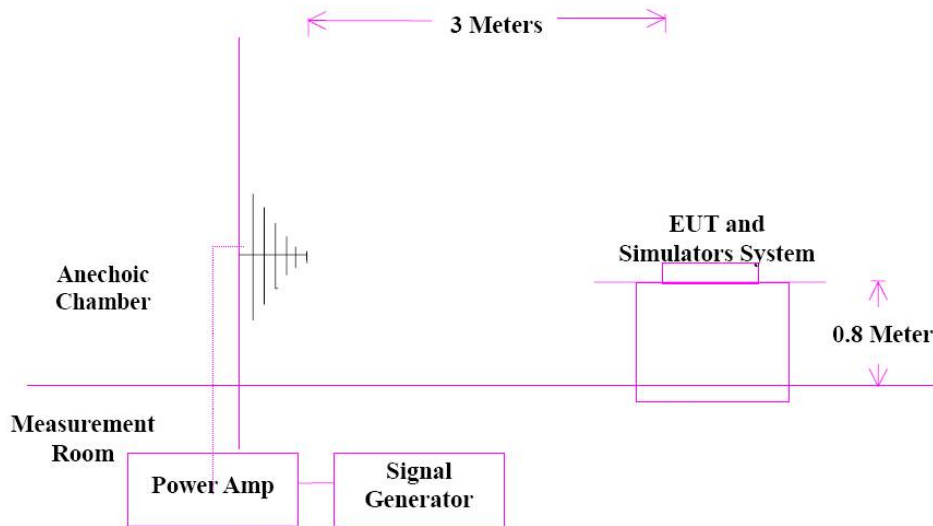

5.5.2 Test Equipments

Description	Manufacturer	Model Number	Serial Number	Cal. Due
SIGNAL GENERATOR	Rohde & Schwarz	SMB 100A	108252	08. 13. 2016
BROADBAND AMPLIFIER	Rohde & Schwarz	BBA100	101239	08. 13. 2016
BROADBAND AMPLIFIER	AR	100S1G6M1	579931	08. 13. 2016
POWER METER	Rohde & Schwarz	NRP2	103475	08. 13. 2016
AVG POWER SENSOR	Rohde & Schwarz	NRP-Z91	102526	08. 13. 2016
AVG POWER SENSOR	Rohde & Schwarz	NRP-Z91	102527	08. 13. 2016
Stacked Log.-Per. Antenna	Schwarzbeck	STLP 9128 D	9128D038	-
RS CHAMBER (EMI 18 GHz)	SEMITEC	-	-	-

5.5.3 Test Environments

Ambient Temperatures :	15 °C ~ 35 °C
Relative Humidity :	30 % R.H. ~ 75 % R.H.
Atmospheric Pressure :	86.0 kPa ~ 106.0 kPa

5.5.4 Test Levels

Frequency Range :	80 MHz to 2 700 MHz
Field Strength :	10 V/m(3 V/m, 1 V/m)
Modulation :	80 % Amplitude Modulation (1 kHz) Pulse Modulation (1 Hz (0.5 s ON: 0.5 s OFF))
Distance of ANT-E.U.T :	3 meters
Antenna Polarity :	Horizontal and Vertical
Frequency Step :	1 %
Performance Criteria :	A

5.5.5 Test Procedures

The E.U.T is set into operation and was monitored for variations in performance. The test signal start frequency (80 MHz) and stop frequency (2 700 MHz) were set, including the field strength at 10 V/m(3 V/m, 1 V/m), 80 % modulated through immunity test software. The software maintains the necessary field strength through the frequency range, with the transmitting antenna horizontally polarized. If an error is detected, the field is reduced until the error is not repeatable, the field is then manually increased until the error begins to occur. This threshold level, the frequency and the error created are noted before continuing. The test is then repeated with vertical polarization, using the same test configuration for all four sides.

5.5.6 Test Results

According to the data in section 5.5.7, the E.U.T complied with the EN 61000-4-3 standards, and detailed test results are found in the following test data.

5.5.7 Test Data

Temperature: 22.6 °C Humidity: 43.5 % R.H. Test Date: 10. 05. 2015 Tested by: Kang Hyeon, Kim

■ D-SUB Mode

No.	Test Point	Performance Results		Remarks
		Horizontal	Vertical	
1	Front	Complied	Complied	-
2	Rear	Complied	Complied	-
3	Right Side	Complied	Complied	-
4	Left Side	Complied	Complied	-

■ HDMI Mode

No.	Test Point	Performance Results		Remarks
		Horizontal	Vertical	
1	Front	Complied	Complied	-
2	Rear	Complied	Complied	-
3	Right Side	Complied	Complied	-
4	Left Side	Complied	Complied	-

This report shall not be reproduced except in full, without the written approval of KES Co., Ltd.
 The test results in the report only apply to the tested sample.

Video Mode

No.	Test Point	Performance Results		Remarks
		Horizontal	Vertical	
1	Front	Complied	Complied	-
2	Rear	Complied	Complied	-
3	Right Side	Complied	Complied	-
4	Left Side	Complied	Complied	-

Performance Results

- A: Normal performance within the specification limits.
- B: Temporary degradation or loss of function or performance which is self-recoverable.
- C: Temporary degradation or loss of function or performance which requires operator intervention or system reset.

5.6 Fast Transient Immunity

5.6.1 Test Description

The E.U.T and all local support equipment were placed a non-metallic support 0.8 m above a reference ground plane (RGP) and was put into operation according to the specified operating mode. If the E.U.T has a non-detachable supply cable more than 1 m long, the excess length of this cable was gathered into a flat coil with a 0.4 m diameter and situated at a distance of 0.1 m above the RGP.

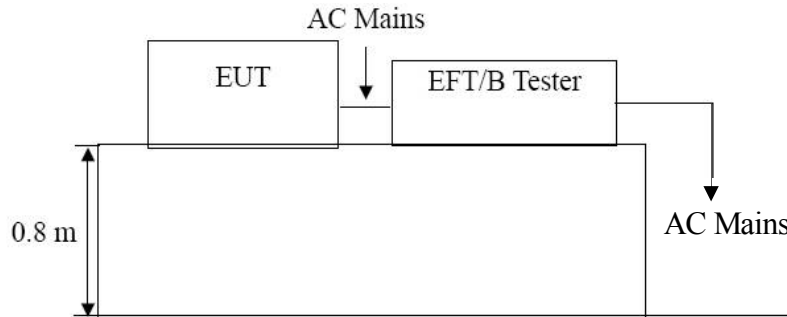

5.6.2 Test Equipments

Description	Manufacturer	Model Number	Serial Number	Cal. Due
Ultra Compact Simulator	EMC TEST	UCS 500 N5	V0936105120	07. 14. 2016
Motorized Variac	EMC TEST	MV2616	V0936105123	07. 14. 2016
Capacitive Coupling Clamp	EMC TEST	HFK	070925	07. 14. 2016

5.6.3 Test Environments

Ambient Temperatures : 15 °C ~ 35 °C
 Relative Humidity : 25 % R.H. ~ 75 % R.H.
 Atmospheric Pressure : 86.0 kPa ~ 106.0 kPa

5.6.4 Test Levels

Open Circuit Output Test Voltage :	<input checked="" type="checkbox"/> Power Supply AC; ± 2 kV <input type="checkbox"/> Power Supply DC; ± 1 kV <input checked="" type="checkbox"/> I/O Signal, Data and Control ports; ± 1 kV
Repetition Frequency of the Impulses :	100 kHz
Polarity :	Positive and Negative
Rise Time of One Pulse :	5 ns ± 30 %
Impulse Duration :	50 ns ± 30 %
Burst Duration :	15 ms ± 20 %
Burst Period :	300 ms ± 20 %
Performance Criteria :	B

5.6.5 Test Procedure

The E.U.T was connected to the test equipment, and monitored for performance. The test level was set and the test signal was applied for 200 seconds. A test signal of ± 1 kV, and ± 2 kV was Coupled to Line and Ground, Neutral and Ground, Line plus Neutral and Ground, and Protective Earth and Ground. When an error occurs, the test level is reduced until the error recovers and then increased until the threshold level is reached. This threshold and the error conditions were noted. This procedure was then repeated for the other coupling modes.

5.6.6 Test Results

According to the data in section 5.6.7, the E.U.T complied with the EN61000-4-4 standards, and detailed test results are found in the following test data.

5.6.7 Test Data

Temperature: 22.6 °C Humidity: 43.5 % R.H. Test Date: 10. 05. 2015 Tested by: Kang Hyeon, Kim

■ D-SUB Mode

On AC Power Supply, Protective Earth(PE) ports

No.	Test Point	Test Level	Performance Results		Remarks
			+Burst	-Burst	
1	L1	± 2 kV	A	A	-
2	L2	± 2 kV	A	A	-
3	PE	± 2 kV	A	A	-
4	L1-L2	± 2 kV	A	A	-
5	L1-PE	± 2 kV	A	A	-
6	L2-PE	± 2 kV	A	A	-
7	L1-L2-PE	± 2 kV	A	A	-

On DC Power Supply

No.	Test Point	Test Level	Performance Results		Remarks
			+Burst	-Burst	
1	-	± 1 kV	-	-	-
2	-	± 1 kV	-	-	-
3	-	± 1 kV	-	-	-

On I/O Signal, Data and Control ports

No.	Test Point	Test Level	Performance Results		Remarks
			+Burst	-Burst	
1	-	± 1 kV	-	-	-



■ **HDMI Mode**

On AC Power Supply, Protective Earth(PE) ports

No.	Test Point	Test Level	Performance Results		Remarks
			+Burst	-Burst	
1	L1	± 2 kV	A	A	-
2	L2	± 2 kV	A	A	-
3	PE	± 2 kV	A	A	-
4	L1-L2	± 2 kV	A	A	-
5	L1-PE	± 2 kV	A	A	-
6	L2-PE	± 2 kV	A	A	-
7	L1-L2-PE	± 2 kV	A	A	-

On DC Power Supply

No.	Test Point	Test Level	Performance Results		Remarks
			+Burst	-Burst	
1	-	± 1 kV	-	-	-
2	-	± 1 kV	-	-	-
3	-	± 1 kV	-	-	-

On I/O Signal, Data and Control ports

No.	Test Point	Test Level	Performance Results		Remarks
			+Burst	-Burst	
1	-	± 1 kV	A	A	-

■ **Video Mode**

On AC Power Supply, Protective Earth(PE) ports

No.	Test Point	Test Level	Performance Results		Remarks
			+Burst	-Burst	
1	L1	± 2 kV	A	A	-
2	L2	± 2 kV	A	A	-
3	PE	± 2 kV	A	A	-
4	L1-L2	± 2 kV	A	A	-
5	L1-PE	± 2 kV	A	A	-
6	L2-PE	± 2 kV	A	A	-
7	L1-L2-PE	± 2 kV	A	A	-

On DC Power Supply

No.	Test Point	Test Level	Performance Results		Remarks
			+Burst	-Burst	
1	-	± 1 kV	-	-	-
2	-	± 1 kV	-	-	-
3	-	± 1 kV	-	-	-

On I/O Signal, Data and Control ports

No.	Test Point	Test Level	Performance Results		Remarks
			+Burst	-Burst	
1	BNC	± 1 kV	A	A	-

Performance Results

- A: Normal performance within the specification limits.
- B: Temporary degradation or loss of function or performance which is self-recoverable.
- C: Temporary degradation or loss of function or performance which requires operator intervention or system reset.

5.7 Surge Immunity

5.7.1 Test Description

The E.U.T and all local support equipment was placed on a non-metallic support 0.8 m above a reference ground plane (RGP) and was put into operation according to the specified operating mode.

5.7.2 Test Equipments

Description	Manufacturer	Model Number	Serial Number	Cal. Due
Ultra Compact Simulator	EM TEST	UCS 500 N5	V0936105120	07. 14. 2016
MotorVariac	EM TEST	MV2616	V0936105123	07. 14. 2016

5.7.3 Test Environments

Ambient Temperatures :	15 °C ~ 35 °C
Relative Humidity :	25 % R.H. ~ 75 % R.H.
Atmospheric Pressure :	86.0 kPa ~ 106.0 kPa

5.7.4 Test Levels

Open Circuit Test Voltage :	<input checked="" type="checkbox"/> AC Power; ± 0,5 kV & ± 1 kV line-to-line, <input checked="" type="checkbox"/> AC Power; ± 0,5 kV & ± 1 kV & ± 2 kV line-to-ground <input type="checkbox"/> DC Power; ± 0,5 kV & ± 1 kV line-to-ground <input checked="" type="checkbox"/> Data and Control Line; ± 0,5 kV & ± 1 kV line-to-ground
Open Circuit Voltage Waveform :	1.2/50 microsecond
Short Circuit Current Waveform :	8/20 microsecond
Number of Tests :	5 positive and 5 negative
Repetition Rate :	1/min
Performance Criteria :	B

5.7.5 Test Procedure

The surges have to be applied line to line and line(s) and ground. In case of testing line to ground the test voltage has to be applied successively between each of the lines and ground, if there is no other specification. All lower levels including the selected test level must be satisfied. For testing the secondary protection the output voltage of the generator must be increased up to the worst case voltage break down level of the primary protection.

5.7.6 Test Results

According to the data in section 5.7.7, the E.U.T complied with the EN61000-4-5 standards, and detailed test results are found in the following test data.

5.7.7 Test Data

Temperature: 22.6 °C Humidity: 43.5 % R.H. Test Date: 10. 05. 2015 Tested by: Kang Hyeon, Kim

■ D-SUB Mode

On AC Power Supply, Protective Earth(PE) ports

No.	Test Point	Test Level	Performance Results		Remarks
			+Surge	-Surge	
1	L1-L2	± 2 kV	A	A	-
2	L1-PE	± 2 kV	A	A	-
3	L2-PE	± 2 kV	A	A	-

On I/O Signal, Data and Control ports

No.	Test Point	Test Level	Performance Results		Remarks
			+Surge	-Surge	
-	-	-	-	-	-

■ HDMI Mode

On AC Power Supply, Protective Earth(PE) ports

No.	Test Point	Test Level	Performance Results		Remarks
			+Surge	-Surge	
1	L1-L2	± 2 kV	A	A	-
2	L1-PE	± 2 kV	A	A	-
3	L2-PE	± 2 kV	A	A	-

On I/O Signal, Data and Control ports

No.	Test Point	Test Level	Performance Results		Remarks
			+Surge	-Surge	
-	-	-	-	-	-

■ **Vedio Mode**

On AC Power Supply, Protective Earth(PE) ports

No.	Test Point	Test Level	Performance Results		Remarks
			+Surge	-Surge	
1	L1-L2	± 2 kV	A	A	-
2	L1-PE	± 2 kV	A	A	-
3	L2-PE	± 2 kV	A	A	-

On I/O Signal, Data and Control ports

No.	Test Point	Test Level	Performance Results		Remarks
			+Surge	-Surge	
-	-	-	-	-	-

Performance Results

- A: Normal performance within the specification limits.
- B: Temporary degradation or loss of function or performance which is self-recoverable.
- C: Temporary degradation or loss of function or performance which requires operator intervention or system reset.

5.8 Radio-frequency continuous conducted Immunity

5.8.1 Test Descriptions

The E.U.T and all local support equipment were placed on a non-metallic support 0.1 m above a reference ground plane (RGP) and was put into operation according to the specified operating mode.

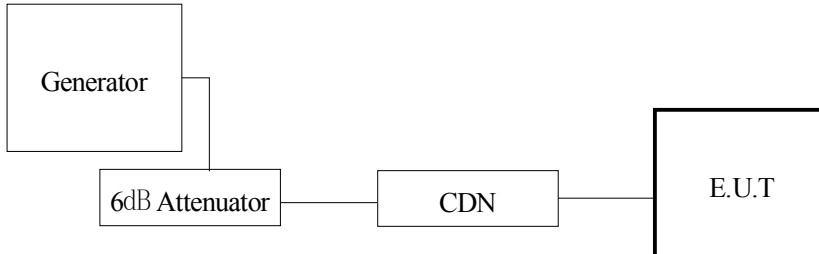

5.8.2 Test Equipments

Description	Manufacturer	Model Number	Serial Number	Cal. Due
Continuous Wave Simulator	EM TEST	CWS 500N1	P1251106910	04. 01. 2016
6dB Attenuator	EM TEST	ATT6	1208-34	08. 13. 2016
CDN	EM TEST	CDN-M2/M3N	0909-06	08. 13. 2016
EM Injection Clamp	EM TEST	EM 101	35943	02. 11. 2016

5.8.3 Test Environments

Ambient Temperatures :	15 °C ~ 35 °C
Relative Humidity :	25 % R.H. ~ 75 % R.H.
Atmospheric Pressure :	86.0 kPa ~ 106.0 kPa

5.8.4 Test Levels

Frequency Range :	150 kHz to 100 MHz
Voltage Level :	10 V(3 V, 1 V)
Modulation :	80 % Amplitude Modulation (1 kHz) Pulse Modulation (1 Hz (0.5 s ON: 0.5 s OFF))
Frequency Step :	1 %
Performance Criteria :	A

5.8.5 Test Procedure

The test was performed with the test generator connected to each of the coupling and decoupling devices in turn while the other non-excited RF-input ports of the coupling devices are terminated by a 50 Ω load resistor. The frequency range is swept from 150 kHz to 100 MHz, using the signal levels established during the setting process, and with the disturbance signal 80 % amplitude modulated with a 1kHz sine wave, pausing to adjust the RF-signal level or to switch coupling device as necessary.

5.8.6 Test Results

According to the data in section 5.8.7, the E.U.T complied with the EN61000-4-6 standards, and detailed test results are found in the following test data.

5.8.7 Test Data

Temperature: 22.6 °C Humidity: 43.5 % R.H. Test Date: 10. 05. 2015 Tested by: Kang Hyeon, Kim

■ D-SUB Mode

On AC Power Supply, Protective Earth(PE) ports

No.	Test Point	Performance Results	Remarks
1	CDN-M2/M3N	A	M3N

On DC Power Supply

No.	Test Point	Performance Results	Remarks
1	-	-	-

On I/O Signal, Data and Control ports

No.	Test Point	Performance Results	Remarks
1	-	-	-

Temperature: 21.0 °C Humidity: 46.7 % R.H. Test Date: 09. 04. 2015 Tested by: Kang Hyeon, Kim

■ HDMI Mode

On AC Power Supply, Protective Earth(PE) ports

No.	Test Point	Performance Results	Remarks
1	CDN-M2/M3N	A	M3N

On DC Power Supply

No.	Test Point	Performance Results	Remarks
1	-	-	-

On I/O Signal, Data and Control ports

No.	Test Point	Performance Results	Remarks
1	-	A	-



■ **Vedio Mode**

On AC Power Supply, Protective Earth(PE) ports

No.	Test Point	Performance Results	Remarks
1	CDN-M2/M3N	A	M3N

On DC Power Supply

No.	Test Point	Performance Results	Remarks
1	-	-	-

On I/O Signal, Data and Control ports

No.	Test Point	Performance Results	Remarks
1	BNC	A	-

Performance Results

- A: Normal performance within the specification limits.
- B: Temporary degradation or loss of function or performance which is self-recoverable.
- C: Temporary degradation or loss of function or performance which requires operator intervention or system reset.

5.9 Voltage Dips and Voltage Interruptions Immunity Measurements

5.9.1 Test Descriptions

The E.U.T and all local support equipment was placed on a non-metallic support 0.8 m above a reference ground plane (RGP) and was put into operation according to the specified operating mode.

5.9.2 Test Equipments

Description	Manufacturer	Model Number	Serial Number	Cal. Due
Ultra Compact Simulator	EM TEST	UCS 500 N5	V0936105120	07. 14. 2016
MotorVariac	EM TEST	MV2616	V0936105123	07. 14. 2016

5.9.3 Test Environments

Ambient Temperatures :	15 °C ~ 35 °C
Relative Humidity :	25 % R.H. ~ 75 % R.H.
Atmospheric Pressure :	86.0 kPa ~ 106.0 kPa

5.9.4 Test Levels

Overshoot/Undershoot of Actual Voltage :	Less than ± 5 % of the change in voltage
Voltage Rise and Fall Time :	Between 1 and 5 microseconds
Test Voltage / Test Frequency :	230 V (ac) / 50 Hz
Frequency Deviation of Test Voltage :	Less than ± 2 % of rated frequency
Number of Tests :	3 times
Test Intervals :	10 sec
Performance Criteria :	B for Voltage Dips C for Voltage Short Interruptions A for Voltage Variation

5.9.5 Test Procedure

For each test any degradation of performance were recorded. The monitoring equipment should be capable of displaying the status of the operational mode of the E.U.T during and after the tests. After each group of tests a full functional check were performed.

5.9.6 Test Results

According to data in section 5.10.7, The E.U.T complied with the EN61000-4-11 Standards, and detailed test results are found in following test data.

5.9.7 Test Data

Temperature: 22.6 °C Humidity: 43.5 % R.H. Test Date: 10. 05. 2015 Tested by: Kang Hyeon, Kim

■ D-SUB Mode

Voltage Dips

No.	Depth	Duration	Performance Results	Remarks
1	30 %	25 T	A	-
2	60 %	10 T	A	-
3	100 %	250 T	A	-
4	20 %	250 T	B	-

Voltage variations

No.	Depth	Duration	Performance Results	Remarks
1	Unom + 10 %	253 V (ac)	A	-
2	Unom - 10 %	195.5 V (ac)	A	-

■ HDMI Mode

Voltage Dips

No.	Depth	Duration	Performance Results	Remarks
1	30 %	25 T	A	-
2	60 %	10 T	A	-
3	100 %	250 T	A	-
4	20 %	250 T	B	-

Voltage variations

No.	Depth	Duration	Performance Results	Remarks
1	Unom + 10 %	253 V (ac)	A	-
2	Unom - 10 %	195.5 V (ac)	A	-



■ **Vedio Mode**

Voltage Dips

No.	Depth	Duration	Performance Results	Remarks
1	30 %	25 T	A	-
2	60 %	10 T	A	-
3	100 %	250 T	A	-
4	20 %	250 T	B	-

Voltage variations

No.	Depth	Duration	Performance Results	Remarks
1	Unom + 10 %	253 V (ac)	A	-
2	Unom - 10 %	195.5 V (ac)	A	-

Performance Results

- A: Normal performance within the specification limits.
- B: Temporary degradation or loss of function or performance which is self-recoverable.
- C: Temporary degradation or loss of function or performance which requires operator intervention or system reset.

6. Test Setup Photographs

6.1 Conducted Emission

■ D-SUB Mode

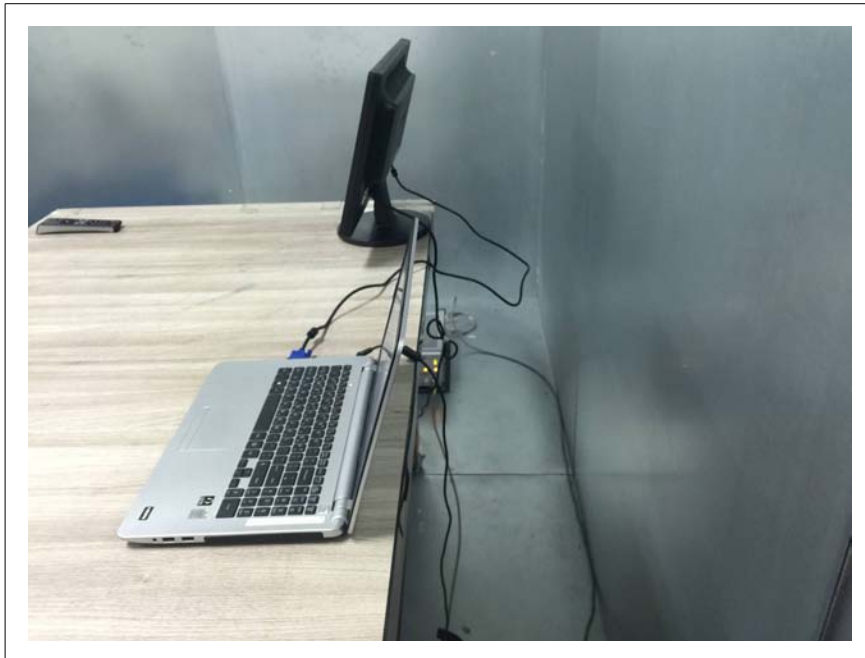
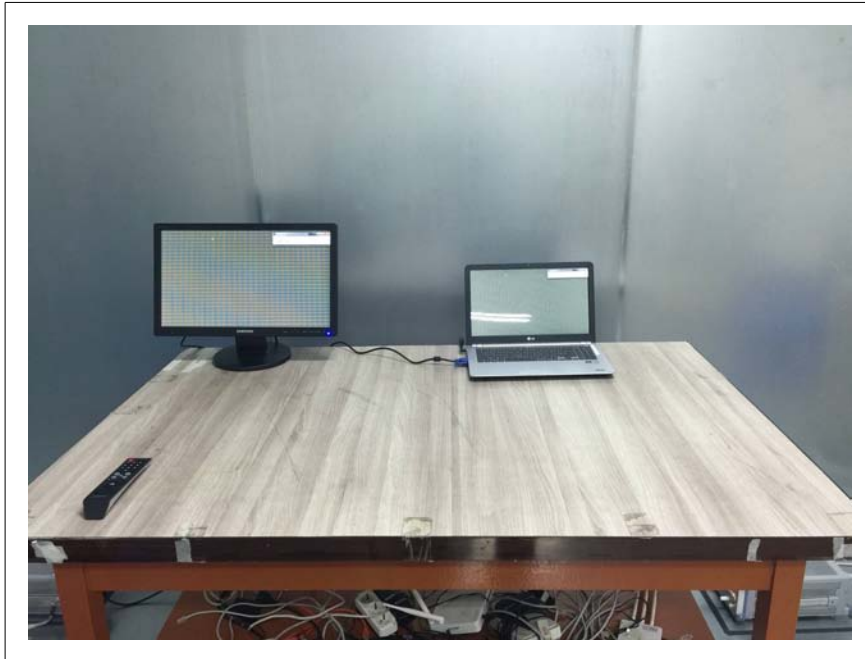

This report shall not be reproduced except in full, without the written approval of KES Co., Ltd.
The test results in the report only apply to the tested sample.

■ HDMI Mode

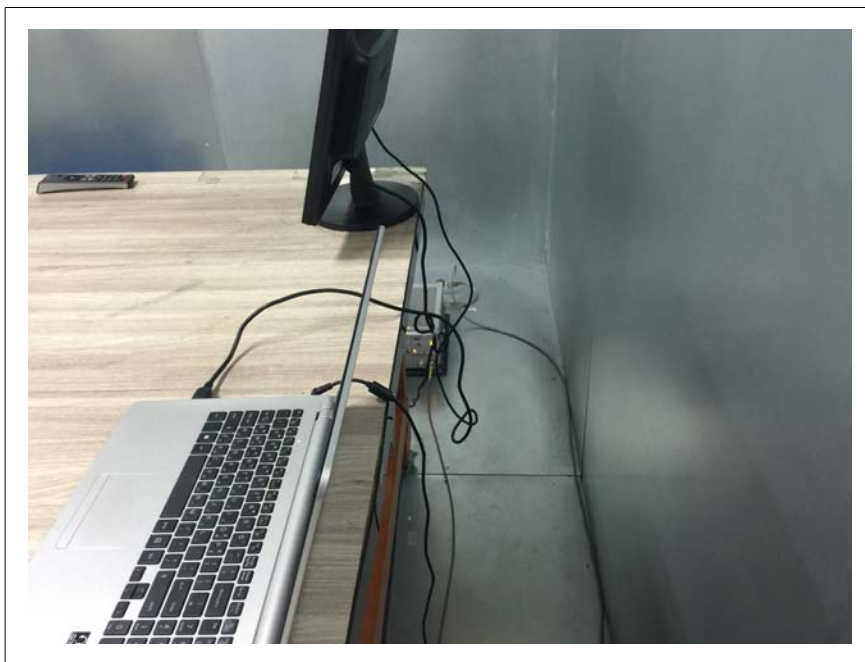

This report shall not be reproduced except in full, without the written approval of KES Co., Ltd.
The test results in the report only apply to the tested sample.

■ Video Mode

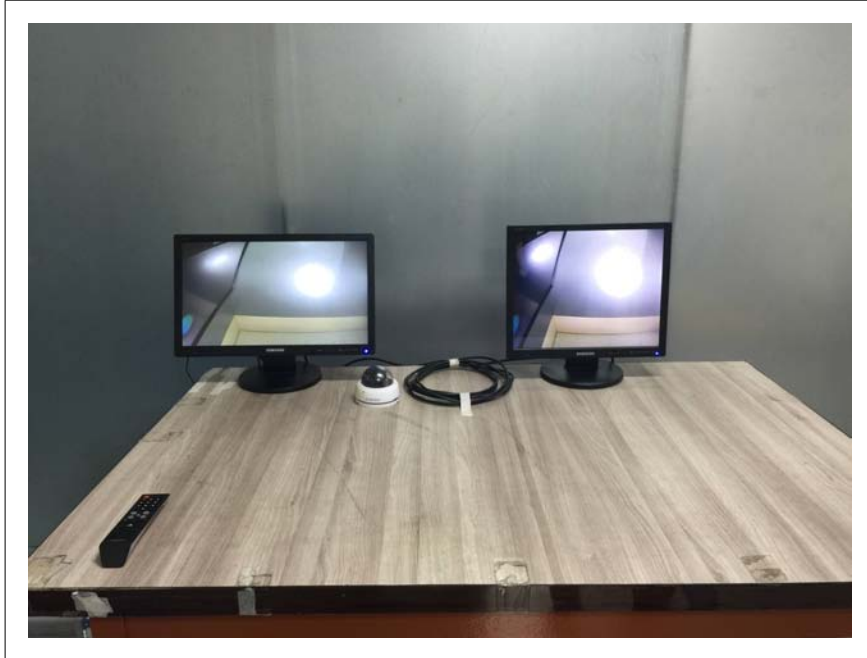

This report shall not be reproduced except in full, without the written approval of KES Co., Ltd.
The test results in the report only apply to the tested sample.

- **Telecommunication Emission**

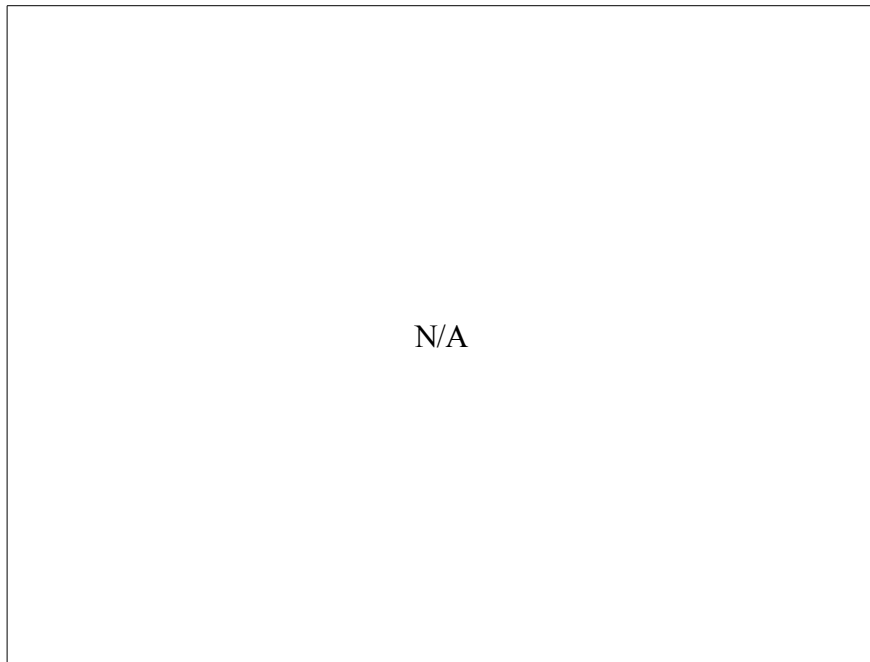
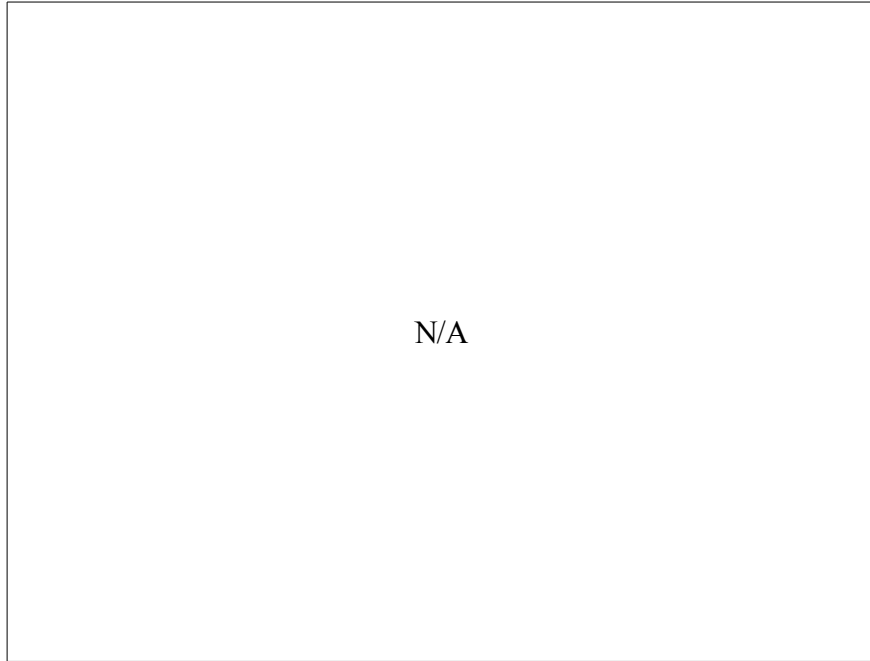

6.2 Radiated Emission

* Below 1 GHz

■ D-SUB Mode



This report shall not be reproduced except in full, without the written approval of KES Co., Ltd.
The test results in the report only apply to the tested sample.

■ HDMI Mode



■ Video Mode

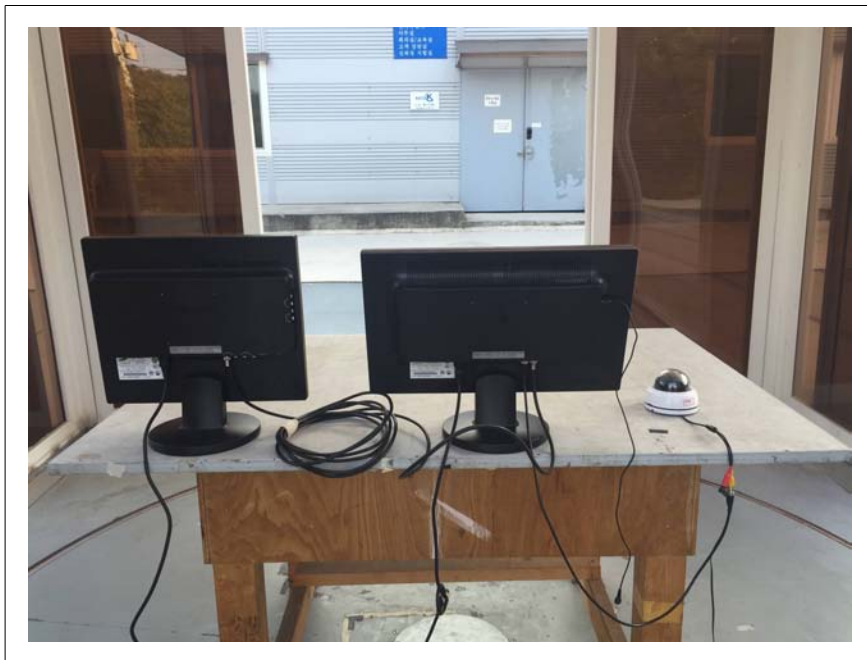

This report shall not be reproduced except in full, without the written approval of KES Co., Ltd.
The test results in the report only apply to the tested sample.

* Above 1 GHz

■ D-SUB Mode

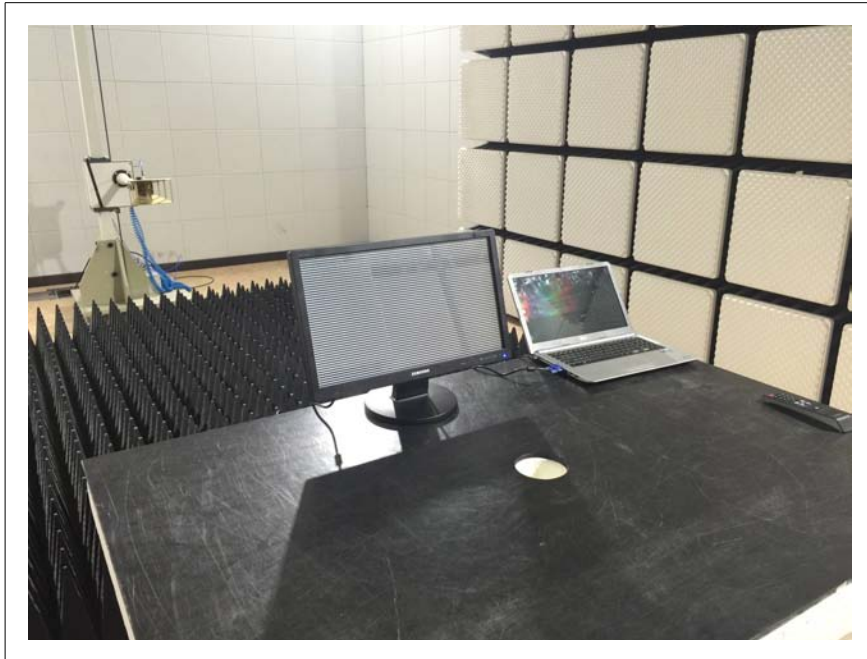

This report shall not be reproduced except in full, without the written approval of KES Co., Ltd.
The test results in the report only apply to the tested sample.

■ HDMI Mode

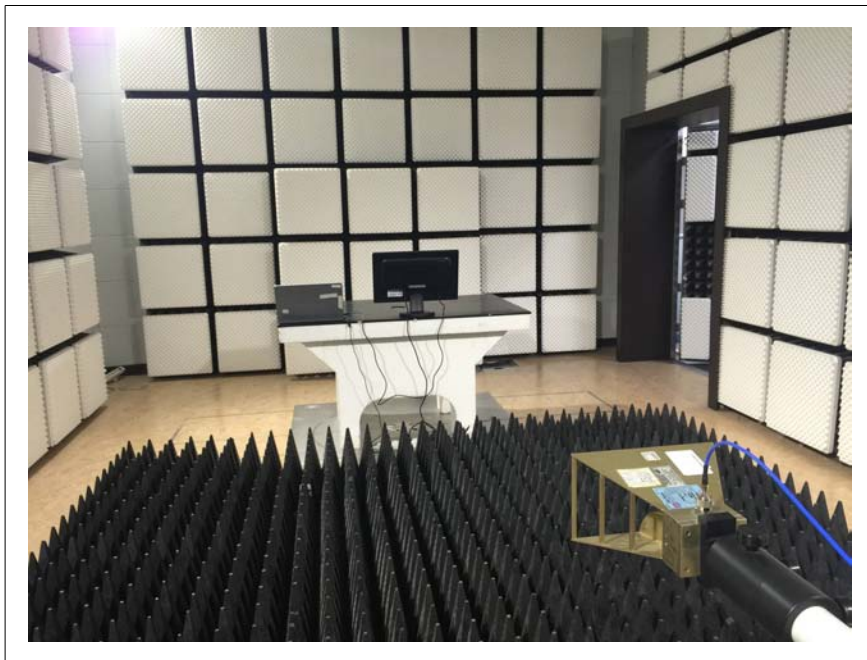

This report shall not be reproduced except in full, without the written approval of KES Co., Ltd.
The test results in the report only apply to the tested sample.

■ Video Mode

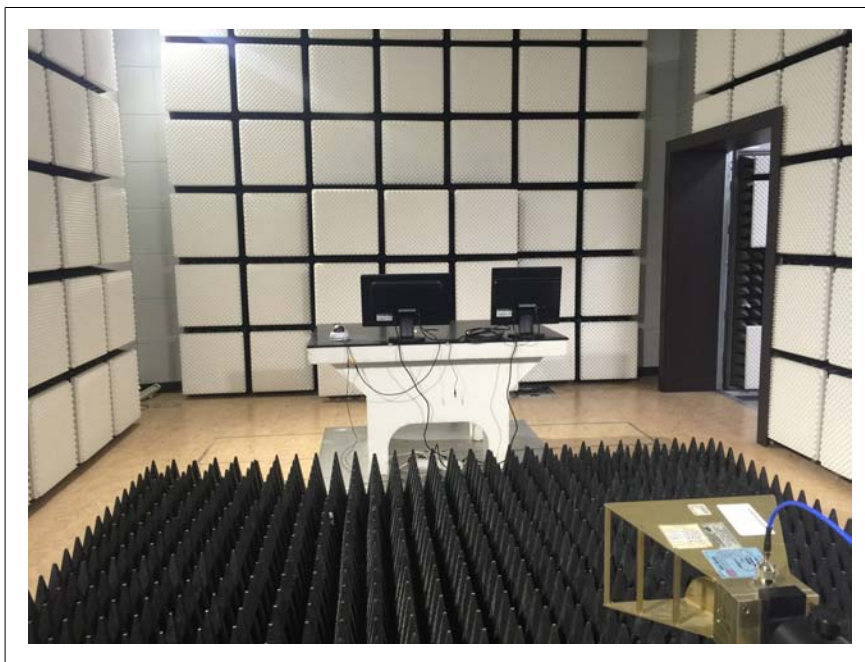

This report shall not be reproduced except in full, without the written approval of KES Co., Ltd.
The test results in the report only apply to the tested sample.

6.3 Harmonics / Voltage Fluctuations

■ D-SUB Mode



■ HDMI Mode



This report shall not be reproduced except in full, without the written approval of KES Co., Ltd.
The test results in the report only apply to the tested sample.

■ Video Mode



This report shall not be reproduced except in full, without the written approval of KES Co., Ltd.
The test results in the report only apply to the tested sample.

6.4 Electrostatic Discharge Immunity

■ D-SUB Mode



■ HDMI Mode



This report shall not be reproduced except in full, without the written approval of KES Co., Ltd.
The test results in the report only apply to the tested sample.

■ Video Mode



This report shall not be reproduced except in full, without the written approval of KES Co., Ltd.
The test results in the report only apply to the tested sample.

■ D-SUB Mode

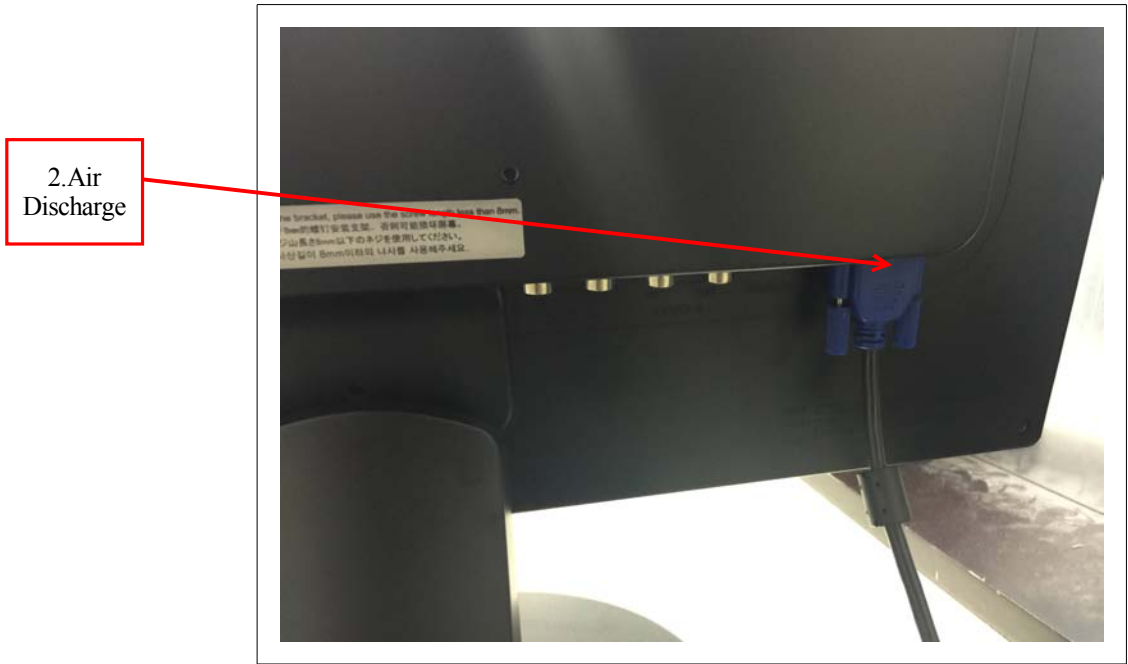
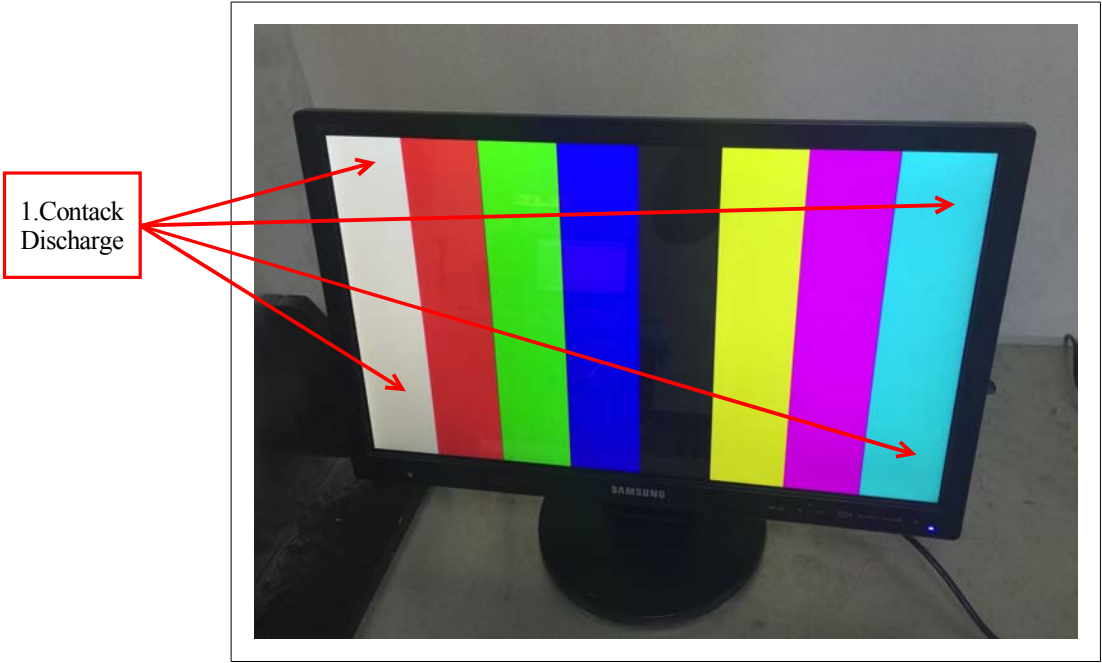

This report shall not be reproduced except in full, without the written approval of KES Co., Ltd.
The test results in the report only apply to the tested sample.

■ HDMI Mode

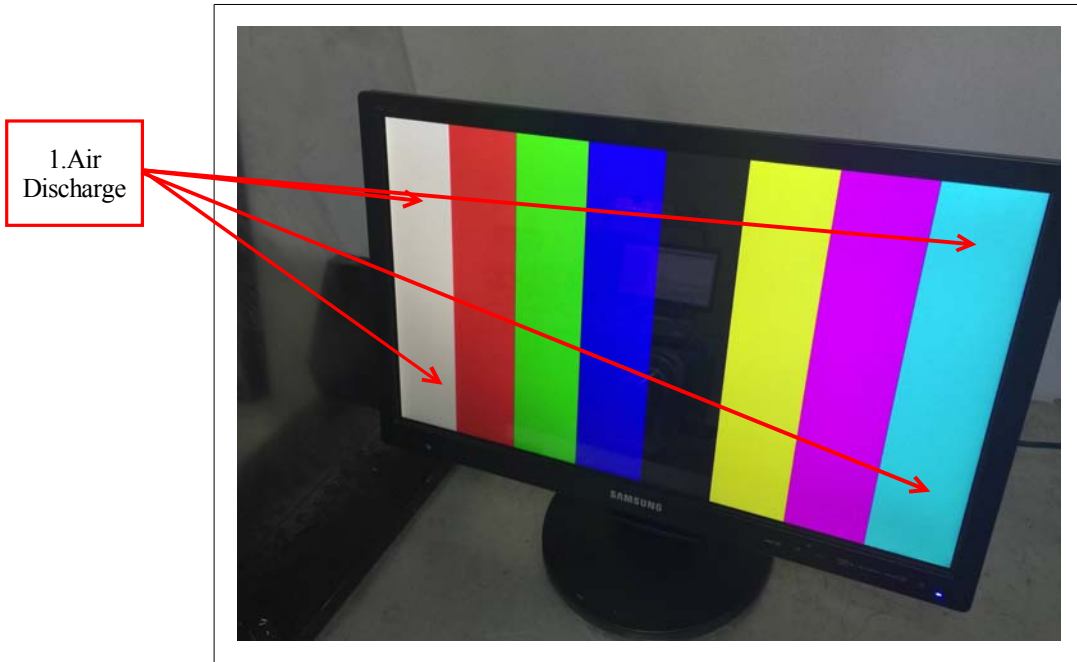

This report shall not be reproduced except in full, without the written approval of KES Co., Ltd.
The test results in the report only apply to the tested sample.

■ Video Mode

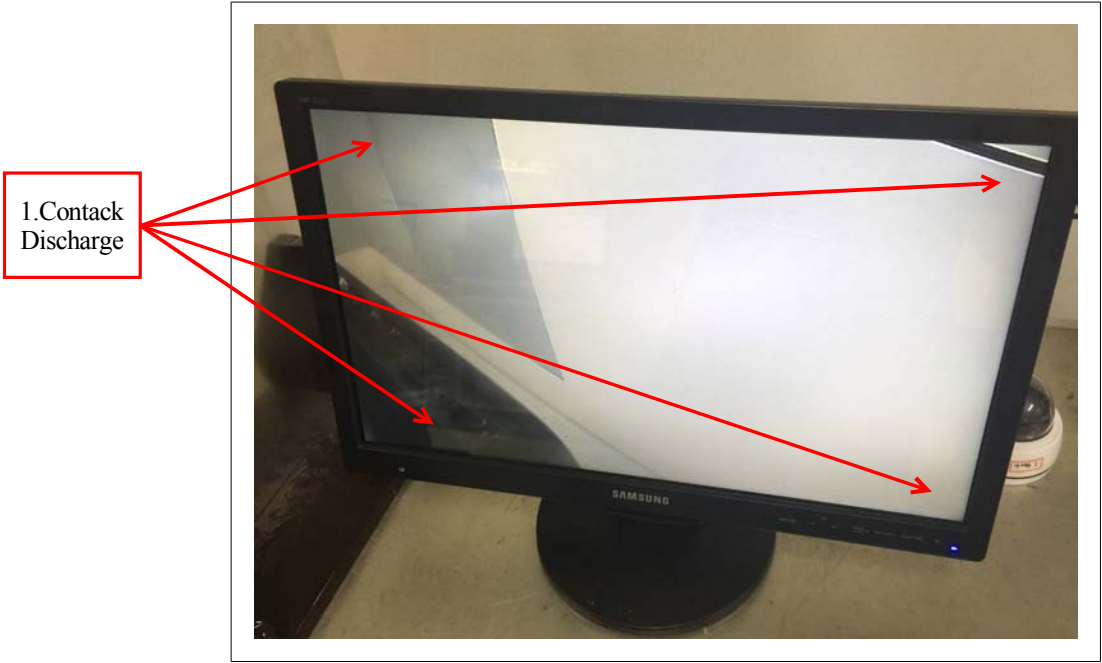

This report shall not be reproduced except in full, without the written approval of KES Co., Ltd.
The test results in the report only apply to the tested sample.

6.5 Radio frequency electromagnetic field immunity

■ D-SUB Mode

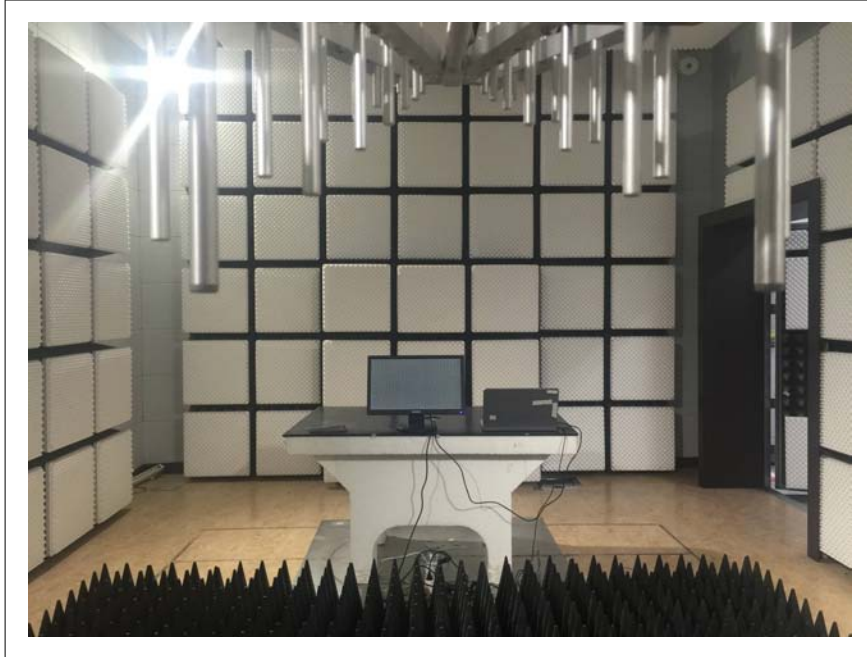

■ HDMI Mode

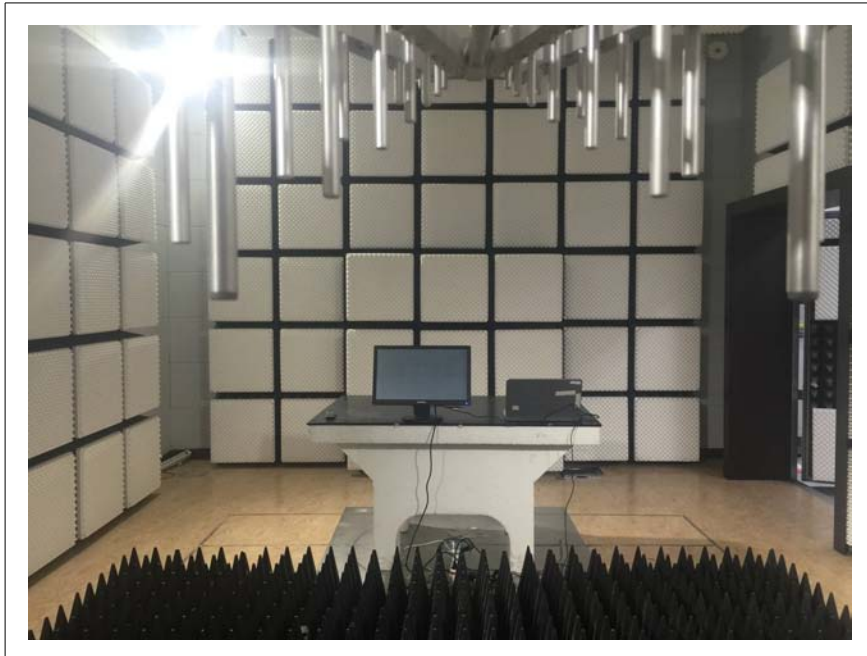

This report shall not be reproduced except in full, without the written approval of KES Co., Ltd.
The test results in the report only apply to the tested sample.

■ Video Mode

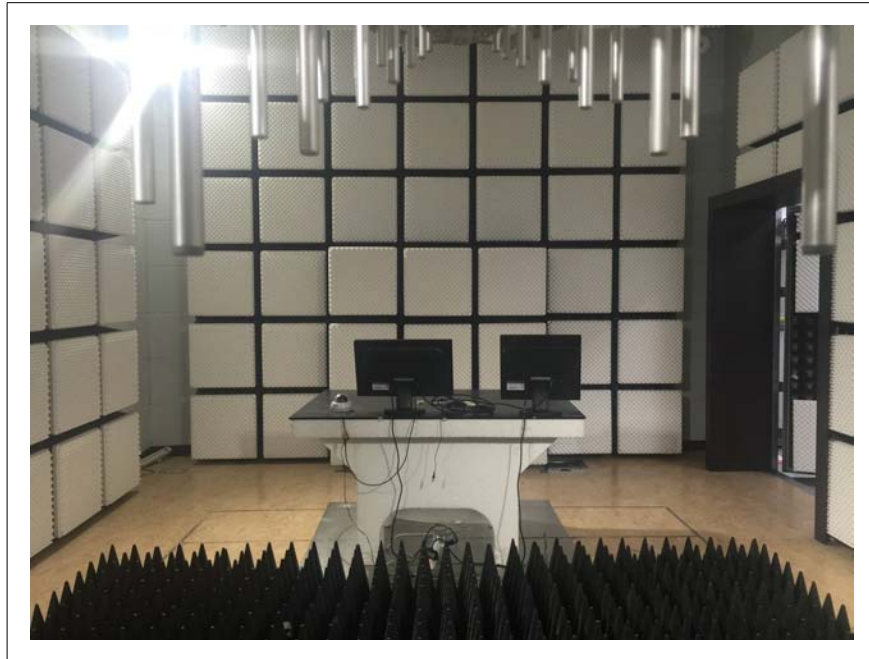

This report shall not be reproduced except in full, without the written approval of KES Co., Ltd.
The test results in the report only apply to the tested sample.

6.6 Fast Transient Immunity

■ D-SUB Mode



■ HDMI Mode



■ Video Mode

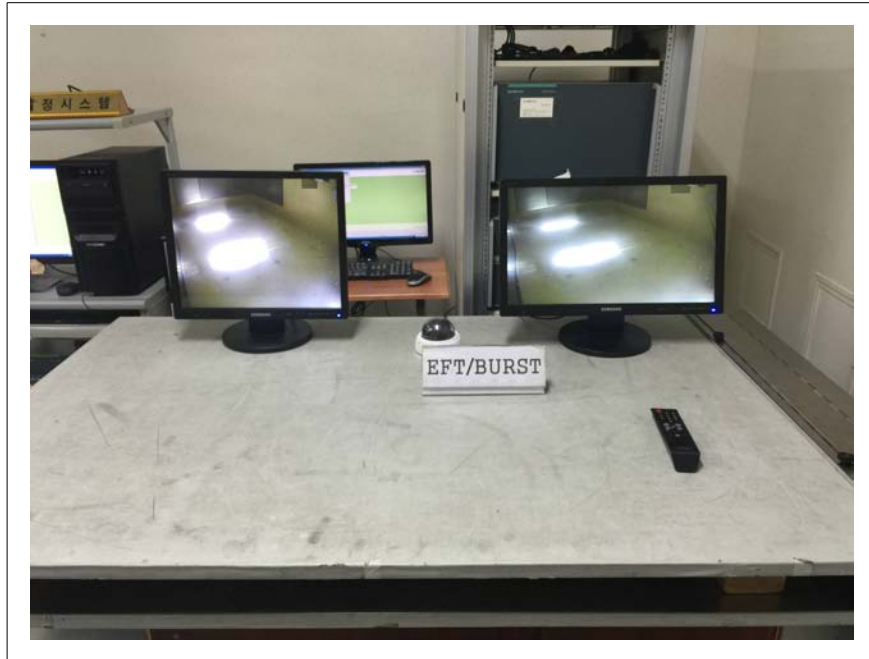

This report shall not be reproduced except in full, without the written approval of KES Co., Ltd.
The test results in the report only apply to the tested sample.

6.7 Surge Immunity

■ D-SUB Mode

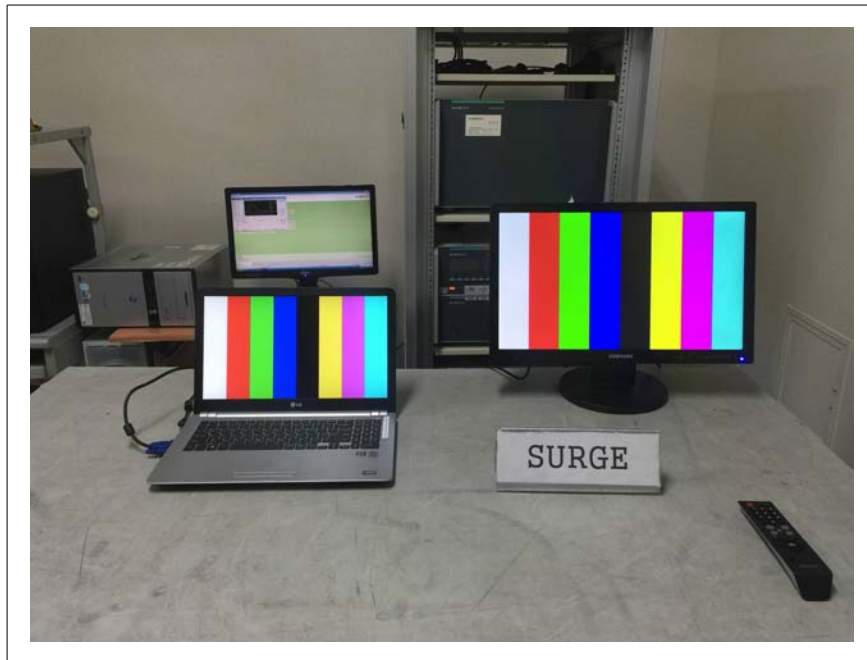

■ HDMI Mode



This report shall not be reproduced except in full, without the written approval of KES Co., Ltd.
The test results in the report only apply to the tested sample.

■ Video Mode



This report shall not be reproduced except in full, without the written approval of KES Co., Ltd.
The test results in the report only apply to the tested sample.

6.8 Radio-frequency continuous conducted Immunity

■ D-SUB Mode

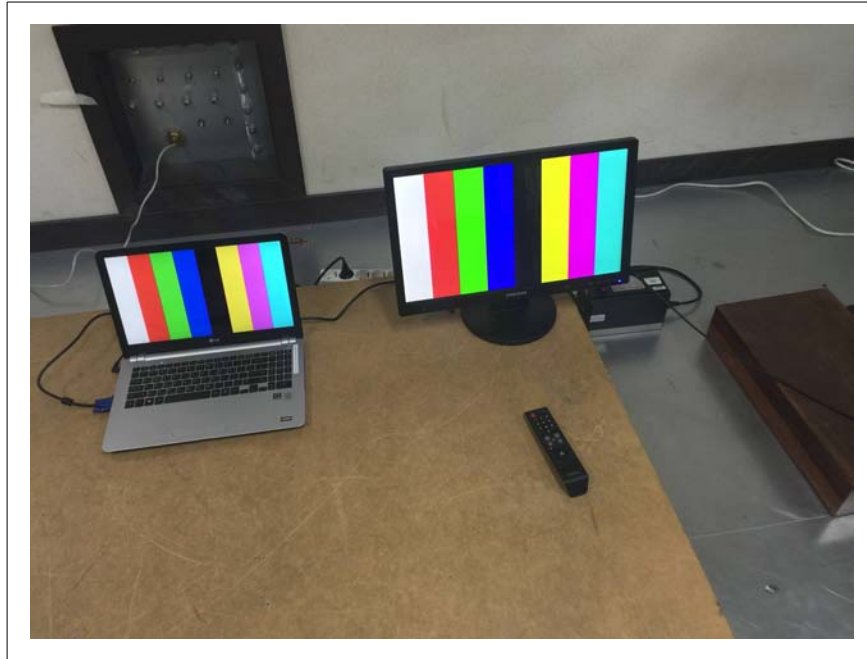

■ HDMI Mode

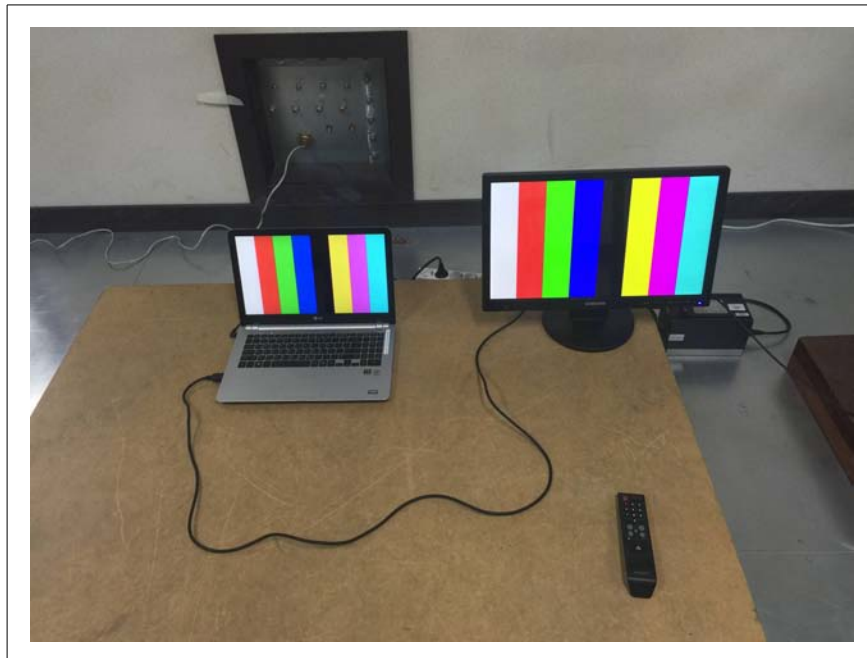

This report shall not be reproduced except in full, without the written approval of KES Co., Ltd.
The test results in the report only apply to the tested sample.

■ Video Mode

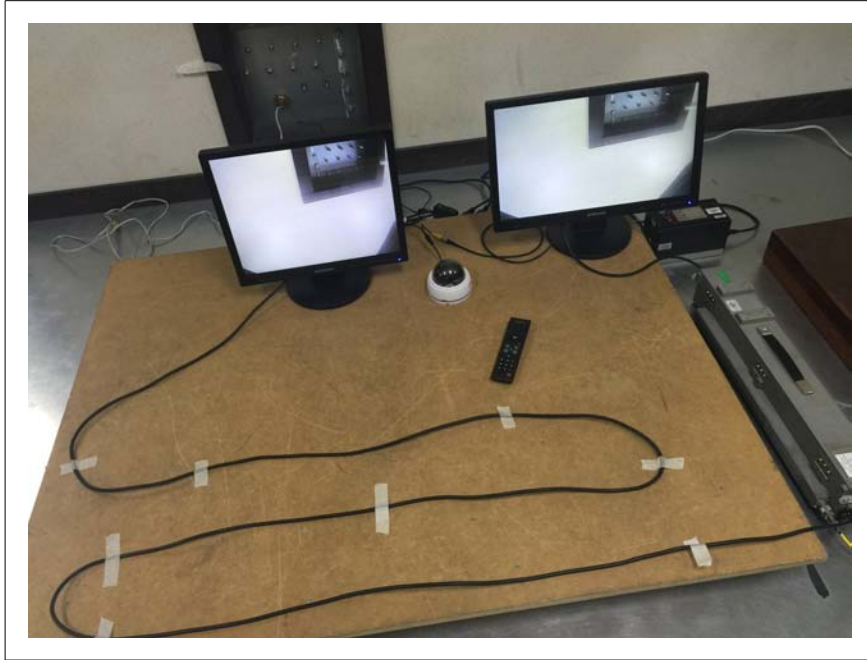

This report shall not be reproduced except in full, without the written approval of KES Co., Ltd.
The test results in the report only apply to the tested sample.

6.9 Voltage Dips and Voltage Interruptions Immunity

■ D-SUB Mode



■ HDMI Mode

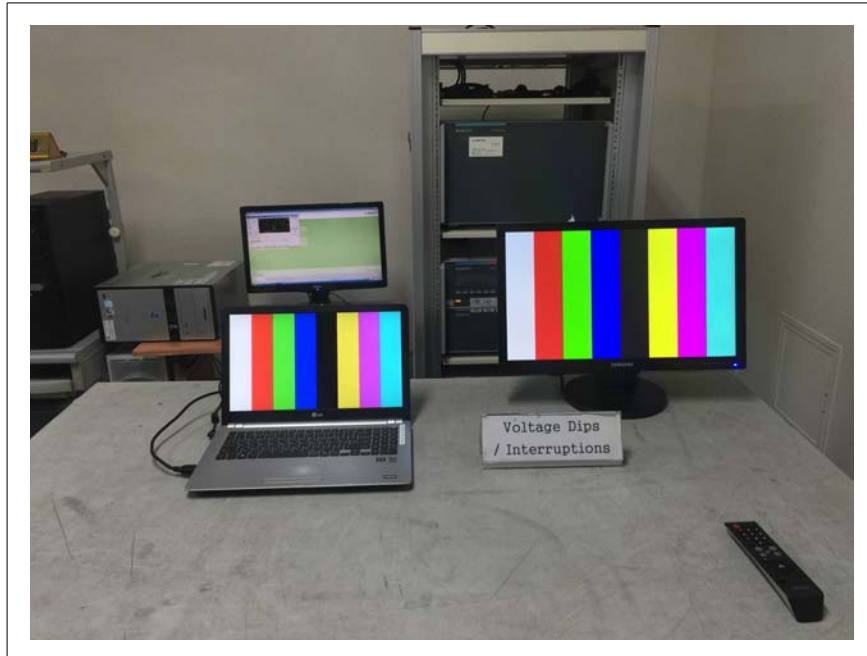

■ Video Mode



This report shall not be reproduced except in full, without the written approval of KES Co., Ltd.
The test results in the report only apply to the tested sample.

7. External Photographs



[FRONT VIEW]



[REAR VIEW]

This report shall not be reproduced except in full, without the written approval of KES Co., Ltd.
The test results in the report only apply to the tested sample.



LCD MONITOR

Model No : SMT-2233

Manufacturer : Weihai Daewoo Electronics Co.,Ltd.

Made in of Chnia



[LABEL VIEW]

8. Internal Photographs



[INTERNAL VIEW]

This report shall not be reproduced except in full, without the written approval of KES Co., Ltd.
The test results in the report only apply to the tested sample.

○ Main Board

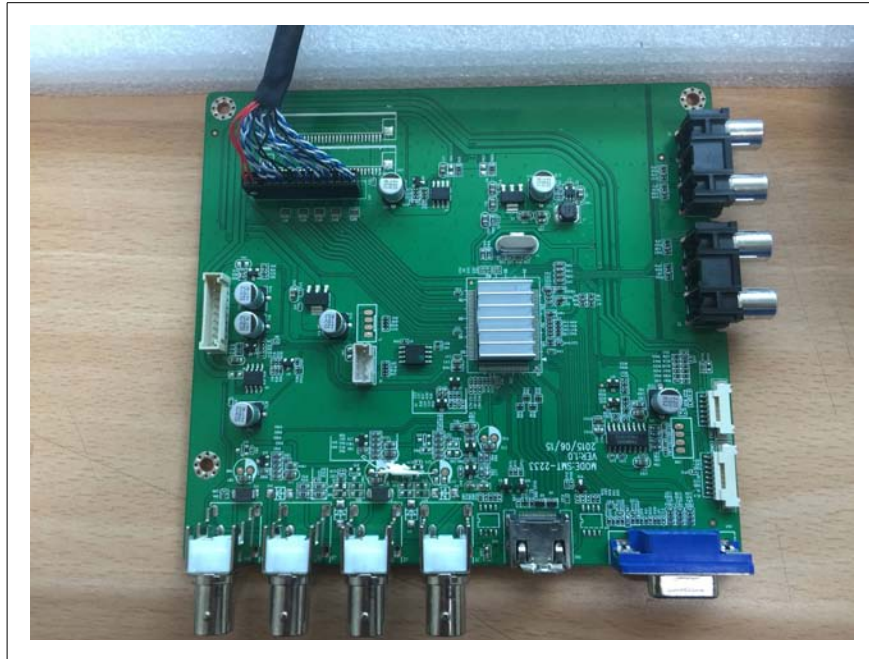

[TOP VIEW]

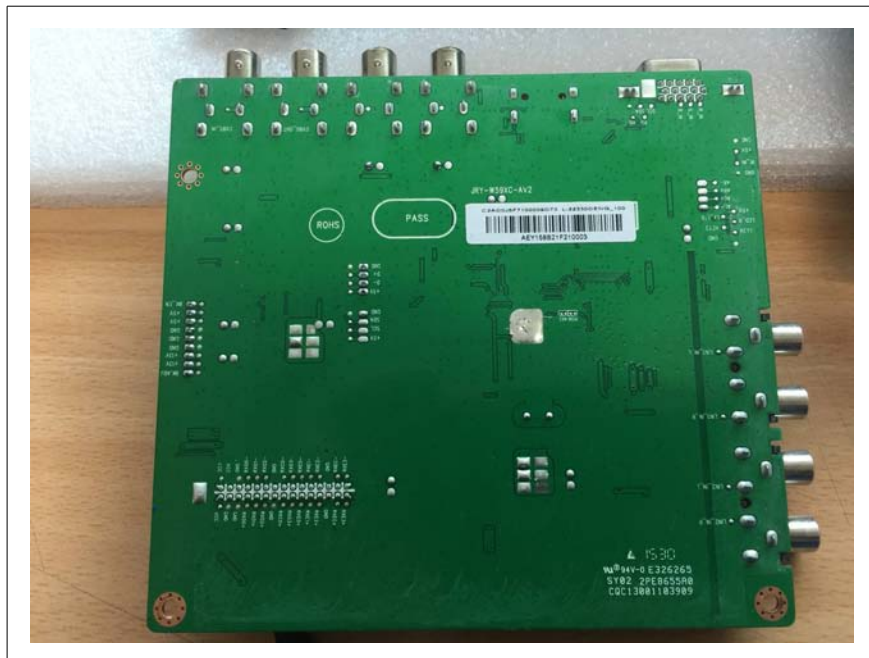

[BOTTOM VIEW]

This report shall not be reproduced except in full, without the written approval of KES Co., Ltd.
The test results in the report only apply to the tested sample.

○ Power Board



[TOP VIEW]



[BOTTOM VIEW]

This report shall not be reproduced except in full, without the written approval of KES Co., Ltd.
The test results in the report only apply to the tested sample.

○ LED Board



[TOP VIEW]



[BOTTOM VIEW]

This report shall not be reproduced except in full, without the written approval of KES Co., Ltd.
The test results in the report only apply to the tested sample.

○ Infrared receiver

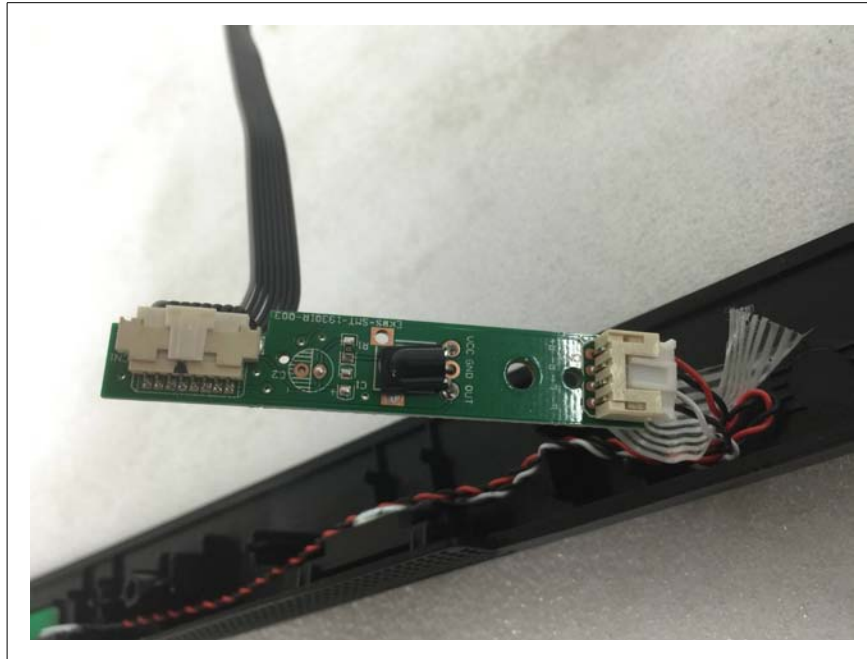

[TOP VIEW]



[BOTTOM VIEW]

This report shall not be reproduced except in full, without the written approval of KES Co., Ltd.
The test results in the report only apply to the tested sample.

○ LCD



[TOP VIEW]



[BOTTOM VIEW]

This report shall not be reproduced except in full, without the written approval of KES Co., Ltd.
The test results in the report only apply to the tested sample.



KES Co., Ltd.

C-3701, 40, Simin-daero 365beon-gil,
Dongan-gu, Anyang-si, Gyeonggi-do, 14057, Korea
Tel: +82-31-425-6200 / Fax: +82-31-424-0450
www.kes.co.kr

Test report No.:
KES-E1-15T0278
Page (105) of (106)

Appendix A - Schematics/Block Diagram

Please see attached document(s).

This report shall not be reproduced except in full, without the written approval of KES Co., Ltd.
The test results in the report only apply to the tested sample.



KES Co., Ltd.

C-3701, 40, Simin-daero 365beon-gil,
Dongan-gu, Anyang-si, Gyeonggi-do, 14057, Korea
Tel: +82-31-425-6200 / Fax: +82-31-424-0450
www.kes.co.kr

Test report No.:
KES-E1-15T0278
Page (106) of (106)

Appendix B - User's Manual

Please see attached document(s).

This report shall not be reproduced except in full, without the written approval of KES Co., Ltd.
The test results in the report only apply to the tested sample.